

4-Cx

DOUBLE OFFSET BUTTERFLY VALVE

Installation, Operation, and Maintenance Manual

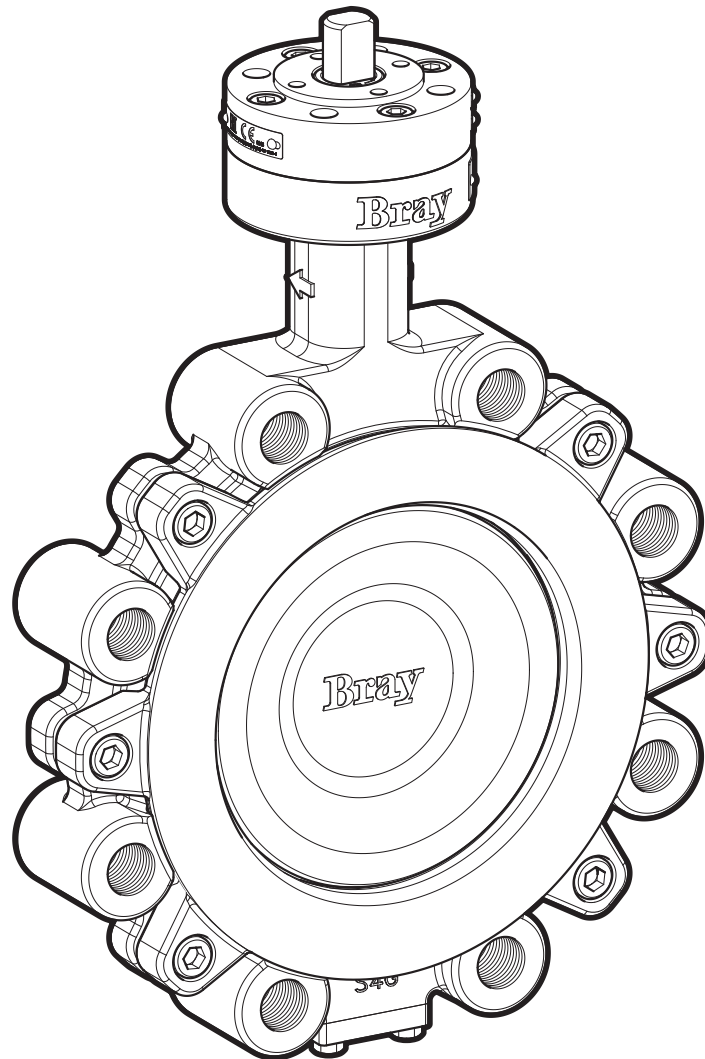

CONTENTS

1.0	DEFINITION OF TERMS	3
2.0	INTRODUCTION	4
3.0	PARTS IDENTIFICATION	5
4.0	VALVE IDENTIFICATION	6
5.0	QUALIFIED PERSONNEL	7
6.0	HANDLING REQUIREMENTS	8
7.0	STORAGE	9
8.0	LIFTING	11
9.0	INSTALLATION CONSIDERATIONS	12
10.0	INSTALLATION PROCEDURE	18
11.0	OPERATION	19
12.0	MAINTENANCE	20
13.0	OPERATOR REMOVAL AND REMOUNTING	21
14.0	STEM SEAL REPLACEMENT	22
15.0	SEAT REPLACEMENT	26
16.0	INSTALL BOTTOM PLATE	28
17.0	TROUBLESHOOTING	29
18.0	RETURN MERCHANDISE AUTHORIZATION	30

**READ AND FOLLOW THESE INSTRUCTIONS CAREFULLY.
SAVE THIS MANUAL FOR FUTURE USE.**

1.0 DEFINITION OF TERMS

1.1 All information within this manual is relevant to the safe operation and proper care of your Bray valve. Please understand the following examples of information used throughout this manual.

X.X IDENTIFIES CHAPTER HEADING

X.XX Identifies and explains sequential procedure to be performed.

NOTE: Provides important information, useful tips, and recommendations related to a procedure.

SAFETY STATEMENTS

The terms DANGER, WARNING, CAUTION, and NOTICE are used in this document to prevent unwanted consequences. Standard symbols and classifications are:



DANGER

Indicates an immediate hazardous situation which, if not avoided, **will** result in death or serious injury and/or property damage.



WARNING

Indicates a potentially hazardous situation which, if not avoided, **could** result in death or serious injury and/or property damage.



CAUTION

Indicates a potentially hazardous situation which, if not avoided, **may** result in minor or moderate injury and/or property damage.



NOTICE

Indicates and provides additional technical information which may not be obvious, even to qualified personnel. The term is not used for personal injury hazards or warnings, but can be used to indicate possible equipment or property damage.

1.2 Compliance with other notes — regarding transport, assembly, operation & maintenance, and about technical documentation (e.g., in the operating instructions, product documentation, or on the product itself) — is essential, to avoid faults which can directly or indirectly cause severe personal injury or property damage.

2.0 INTRODUCTION



NOTICE

Failure to follow these procedures could affect product warranty.

Read and follow these instructions carefully and keep this manual in a safe place for future reference.

Based on over thirty years experience in the butterfly valve industry, Bray can state without question the majority of all field problems for butterfly valves are directly related to poor installation procedures. For this reason, it is very important all distributors educate their customers regarding proper installation of butterfly valves.

2.1 The 4-Cx double offset butterfly valve is precision engineered to comply with European standards and regulations in the most demanding applications. Based on Bray's award winning double eccentric design, the 4-Cx incorporates over 40 years of proven industry performance into a highly versatile valve. Engineered for bi-directional zero leakage and low fugitive emissions, this double offset butterfly valve is certified to the highest standards.

2.2 Valve features include:

- > Bubble tight shutoff provided throughout a wide range of operating conditions.
- > Suitable for both modulating and on/off services, the 4-Cx double offset butterfly valve is easily automated with your choice of manual operators, electric and pneumatic actuators, positioners, and controls.
- > External travel stop prevents over-travel of disc open and close.
- > Uninterrupted gasket sealing faces.
- > Extended body neck provides pipe insulation clearance.
- > Live loaded, fully adjustable, encapsulated, low fugitive emissions stem seal per ISO 15848-1.

2.3 Additional information about 4-Cx double offset butterfly valves — including application data, engineering specifications, and actuator selection — is available from your local Bray distributor or sales representative, and online at **BRAY.COM**.

4-Cx DOUBLE OFFSET BUTTERFLY VALVES

Installation, Operation and Maintenance Manual



3.0 PARTS IDENTIFICATION

ITEM	DESCRIPTION
1	Body
2	Disc
3	Stem
4	Taper Pin
5	Seat
6	Seat Retainer
7	Cap Screw, Seat Retainer
8	Disc Spacer
9	Bearing
10	Bearing Spacer (Optional)
11	Thrust Washer
12	Stem Seals
13	Gland Ring
14	Disc Spring
15	Grounding Spring
16	Gland Washer
17	O-ring, Stem
18	Travel Stop
19	O-ring, Travel Stop
20	O-ring, Gland Retainer
21	Gland Retainer
22	Set Screw
23	Cap Screw, Gland Retainer
24	Gasket, Bottom Plate
25	Bottom Plate
26	Bolt, Bottom Plate
27	Certification Tag
28	Torque Tag
29	Customer Tag
30	Identification Tag
31	Drive Screw
32	Key

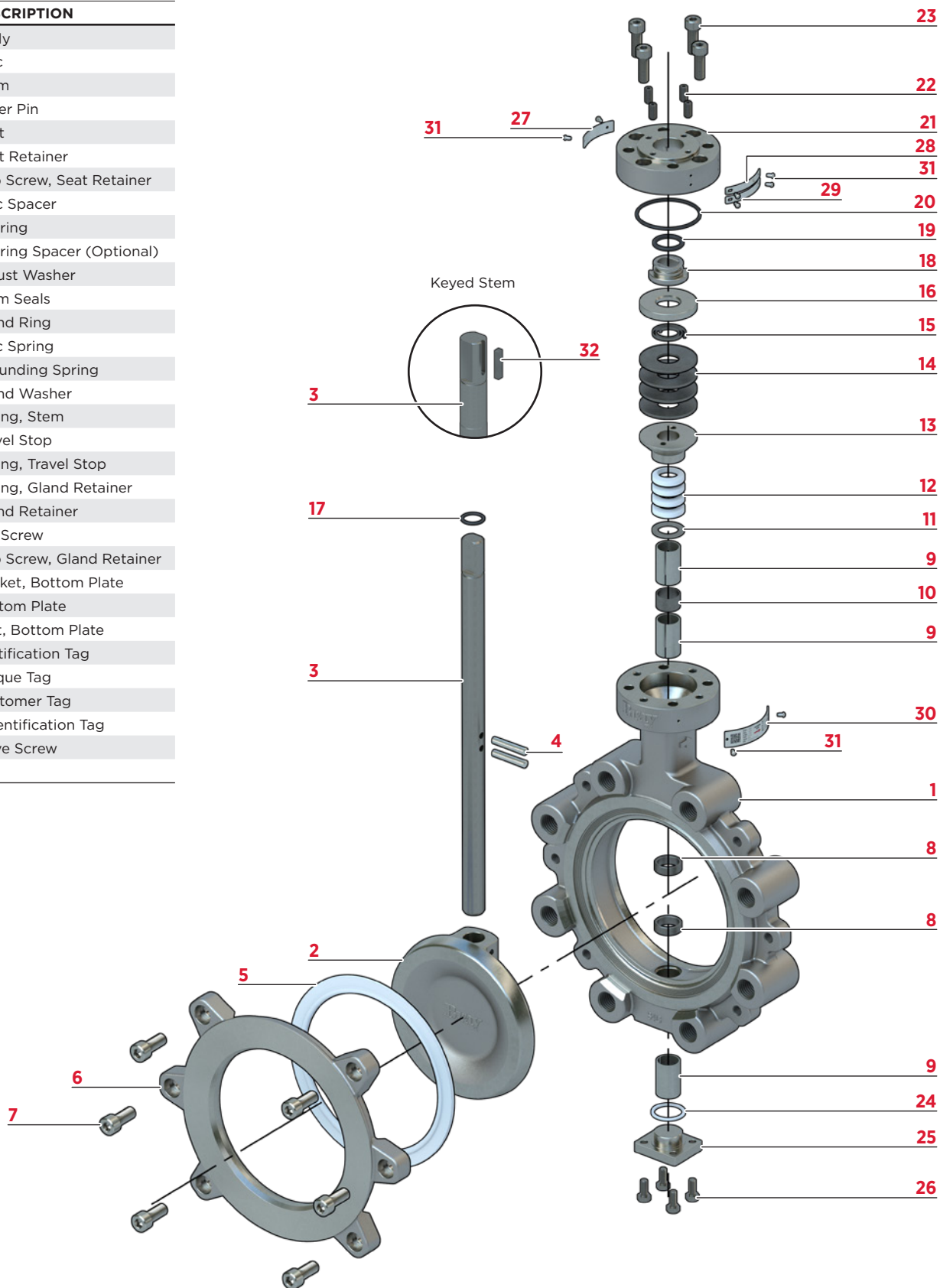

4.0 VALVE IDENTIFICATION



NOTICE

- > Ensure the box is not damaged externally.
- > Remove the valve from the packaging and check for any damage to the valve and its components during transit.
- > Report any damage or discrepancies immediately.
- > Every valve has an identification tag and must not be removed or covered, so that the installed valve remains identifiable.
- > Depending on the region, the valve identification tag may vary.

- 4.1** All valves, actuators, or control products are provided with an identification tag that is unique to each device.

All products for the Cx Line feature a digital valve identification tag. The electronic tagging system — **Bray DIGI-ID™** — ensures that each valve is uniquely and easily identifiable by simply scanning the QR Code on the product identification tag. This allows the operator to gain instant access to all relevant product information. This solution is in accordance with the DIN EN IEC 61406 (DIN Spec 91406) standard.



Scan code for more information
about Bray DIGI-ID™

5.0 QUALIFIED PERSONNEL



NOTICE

Failure to follow these procedures could affect product warranty.

5.1 A **qualified person** in terms of this document is one who is familiar with the installation, commissioning, and operation of the device and who has appropriate qualifications, such as:

- > Is trained in the operation and maintenance of electrical and mechanical equipment and systems in accordance with established safety practices.
- > Is trained or authorized to energize, de-energize, ground, tag, and lock electrical circuits and equipment in accordance with established safety practices.
- > Is trained in the proper use and care of personal protective equipment (PPE) in accordance with established safety practices.
- > In cases where the device is installed in a potentially explosive (hazardous) location — is trained in the commissioning, operation, and maintenance of equipment in hazardous locations.

5.2 **Additional information** about 4-Cx valves — including application data, engineering specifications, and actuator selection — is available from your local Bray distributor or sales representative.

6.0 HANDLING REQUIREMENTS



WARNING

A potential hazard exists with handling valves. Failure to handle valves properly may cause a valve to shift, slip or fall causing serious injury or death and/or equipment damage.



CAUTION

Must be taken during handling to avoid this equipment passing over workers, or over any other place where a possible fall could cause injury or damage.

For handling and/or lifting, the lifting equipment (fasteners, hooks, etc.) must be sized and selected while taking into account the product weight indicated in our packing list and/or delivery note. Lifting and handling must be performed only by qualified personnel.

Fasteners must be protected by plastic covers in sharp corner areas.

In all cases, local safety regulations must be respected.

6.1 Packed Valves

Crates: Lifting and handling of the packed valves in crates will be carried out by a fork lift truck, by means of the appropriate fork hitches.

Cases: The lifting of packed valves in cases will be carried out in the lifting points and in the center of gravity position which has been marked. The transportation of all packed material must be carried out safely and following the local safety regulations.

6.2 Unpacked Valves

Lifting and handling of valves should be carried out by using appropriate means and observing carrying limits. Handling must be carried out on pallets, protecting all machined surfaces to avoid any damage.

With large bore valves, rigging the load must be carried out by using the appropriate tools to prevent the valve from falling or moving during the lifting and handling.

7.0 STORAGE



NOTICE

The packaging is designed to protect the valve only during shipping. If you are not installing the valve immediately after delivery, then you must store it according to these requirements.

Failure to follow these procedures could affect product warranty.

The seat, disc, stem and bushing of the resilient seated butterfly valve should be coated with silicone lubricant unless specified otherwise.

7.1 Short-Term Storage

Short-term storage is defined as storage of valves to allow for project construction and will be installed within a relatively short amount of time (typically one to three months). During short-term storage, the following is required:

The preferred storage location is a clean, dry, protected warehouse. Do not expose the valve to temperature extremes.

End protectors shall remain on the valve ends to prevent the entrance of dirt, debris, or insects/wildlife and should only be removed at the time of valve installation.

Goods shall remain in the original shipping container with the original packaging materials. This packaging method will not protect valves that will be stored outside, uncovered, and unprotected.

Storage of valves in an open, uncovered area is permissible, but requires provisions for inclement weather. The product must be elevated from the ground on a pallet, a shelf, or other suitable surface, and must be covered with a secure, waterproof tarp.



CAUTION

Do not stack the valves on top of each other.

Manually actuated valves may be stored in the vertical or horizontal position. For air or hydraulic actuated valves, the preferred orientation is with the valve and cylinder in the vertical position. Access ports should be secured to prevent unauthorized entry and prevent contamination.

7.2 Long-Term Storage

Long-term storage is defined as storage of valves longer than three months. During long-term storage, the following is required:

The storage location shall be a clean, dry, protected warehouse. Do not expose the valve to temperature extremes.

End protectors shall remain on the valve ends to prevent the entrance of dirt, debris, or insects/wildlife and should only be removed at the time of valve installation.

Product shall remain in the original shipping container with the original packaging materials.



CAUTION

Do not stack the valves on top of each other.

Manually actuated valves may be stored in the vertical or horizontal position. For air or hydraulic actuated valves, the preferred orientation is with the valve and cylinder in the vertical position. Access ports should be secured to prevent unauthorized entry and prevent contamination.

Valves and equipment containing elastomers, including o-rings, must be stored in a climate-controlled warehouse according to SAE-ARP5316D requiring:

- > The ambient relative humidity to be less than 75%.
- > No exposure from direct ultraviolet or sunlight.
- > Protection from ozone generating equipment or combustible gases and vapors.
- > Storage at temperatures below 38°C (100°F), away from direct sources of heat. Preferred temperature range from 4°C to 29°C (40°F to 85°F). If a component is cooled below 15°C (59°F), the entire valve assembly should be allowed to rise above 20°C (68°F) before installing into service.
- > No exposure to ionizing radiation.

7.3 Storage Inspection

Visual inspection shall be performed on a quarterly basis and results recorded. Inspection, as a minimum, shall include reviewing the following:

- > Packaging.
- > Flange covers.
- > Dryness.
- > Cleanliness.

4-Cx DOUBLE OFFSET BUTTERFLY VALVES

Installation, Operation and Maintenance Manual



8.0 LIFTING



WARNING

A potential hazard exists with handling valves. Failure to handle valves properly may cause a valve to shift, slip, or fall — causing serious injury or death and/or equipment damage.



NOTICE

The following information is for reference purposes only.

- > Always use safe and proper techniques for lifting and support.
- > Lift with properly rated lifting equipment.
- > DO NOT lift valves with any adjoining pipe or other equipment attached.
- > Follow jurisdictional safety requirements.

Figure 1: Approved lifting configurations.

NOTES:

- > Keep body level when lifting.
- > Ensure strap is secure around valve.
- > Ensure strap is not twisted.

 **INCORRECT**
Straps through seat opening.



 **CORRECT**
Straps around body or neck.

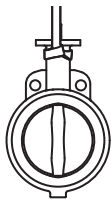

 **INCORRECT**
Straps around actuator body.

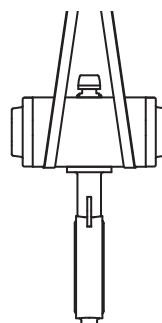

 **CORRECT**
Straps around body or neck.

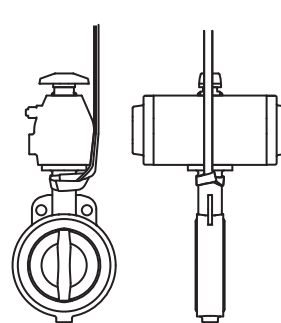

 **INCORRECT**
Straps through seat opening.

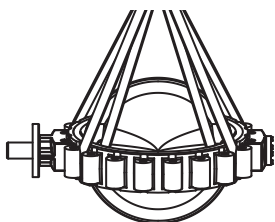

 **CORRECT**
Straps around body.

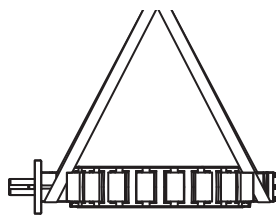

 **INCORRECT**
Straps through gear handwheel.

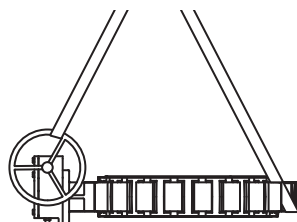

 **CORRECT**
Chains with lifting lugs.

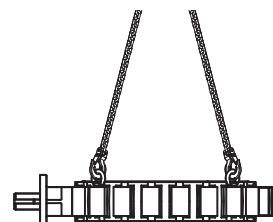

9.0 INSTALLATION CONSIDERATIONS



WARNING

- > Only qualified personnel are allowed to install the valve.
- > Verify line is depressurized before installing, removing, or repairing a valve or operator.
- > Do not pressurize the line without an operator on the valve.
- > The device generates a large mechanical force during normal operation.
- > Observe all applicable safety regulations for valves installed in potentially explosive (hazardous) locations.



CAUTION

- > Risk of crushing the hand or fingers.
- > Do not operate a valve with actuator until it is installed.
- > Do not operate a valve installed at the open end of a pipe section.
- > Never rotate disc beyond full open or closed position. This could cause damage to sealing surfaces.



NOTICE

- > This valve is equipped with external travel stops to prevent disc over-travel. The valve is opened by turning counter-clockwise, closed by turning clockwise. The double “D” flats or keyway at the top of the stem is parallel to the disc edge.
- > For maximum service life, install the valve with the seat retainer upstream. Positive shutoff will be obtained with the valve in either position; however, installation with the seat retainer upstream will give longer service life, especially in erosive services. **(See Figure 2)**
- > For the installation of valves in a pipeline, the same instructions apply as for the flange connection of pipes and similar pipeline elements.

Figure 2: Valve installed with seat retainer upstream.

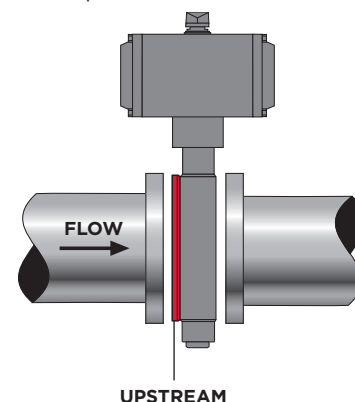

The following instructions apply additionally to valves:

9.1 Piping and Flanged Compatibilities

This valve is designed to be mounted between EN flanges. When the valve is open, the disc will extend into the pipe on both sides of the valve — further on the body side than the seat retainer side of the valve. Piping must be large enough to allow the disc to clear the pipe.

(Table 1 shows the minimum pipe ID allowable.)



CAUTION

When using a pipe with a smaller ID than the recommended minimum inside diameter of pipe with adequate clearance, a chamfer of 45° should be provided on the end of the pipe so that it clears the disc.

Table 1: MINIMUM INSIDE DIAMETER OF PIPE WITH THE RECOMMENDED CLEARANCE

Valve Size DN	Minimum Pipe ID (mm)			
	PN10	PN16	PN25	PN40
80	74.5	74.5	74.5	74.5
100	96.0	96.0	96.0	96.0
150	152.5	152.5	152.5	147.5
200	203.0	203.0	203.0	196.5
250	253.5	253.5	253.5	244.0
300	303.5	303.5	303.5	290.5
350	333.0	333.0	333.0	333.0
400	376.5	376.5	376.5	376.5

9.2 Valves with Spring Return Actuators

9.2.1 Fail Open Assemblies

If the valve is supplied with an actuator, the butterfly valve disc is shipped in the full open position (as no air pressure is present to compress the springs and close the valve disc.) The sealing surface, or disc edge, is therefore exposed. Damage to that surface will cause premature seat failure.



CAUTION

Use caution installing the valve, being careful not to damage the disc edge. It is recommended to:

- > Remove the actuator. Be sure to scribe the valve and actuator to ensure the re-installed actuator is in the exact same quadrant as originally configured.
- > Rotate disc to the closed position.
- > Install the valve.
- > Rotate disc to fully open position.
- > Re-install the actuator ensuring it is in the proper quadrant.

9.3 Valve Location

Butterfly valves should be installed (if possible) a minimum of 6 pipe diameters from other line elements, i.e., elbows, pumps, valves, etc. In instances when 6 pipe diameters are not practical, it is important to achieve as much distance as possible.

Where the butterfly valve is connected to a check valve or pump, use an expansion joint between them to ensure the disc does not interfere with the adjacent equipment.

9.4 Valve Orientation



NOTICE

Bray does not recommend valves be installed in an upside-down position.

In general, Bray recommends the butterfly valve be installed with the stem in the vertical position and the actuator mounted directly above the valve; however, there are those applications as discussed below where the stem should be horizontal.

For slurries, sludge, mine tailing, pulp stock, dry cement, and any media with sediment or particles, Bray recommends the butterfly valve to be installed with the stem in the horizontal position with the lower disc edge opening in the downstream direction.

(Figure 3)

Figure 3: Valve orientation for media with sediment.



INCORRECT

Sediment buildup around lower disc and hub.

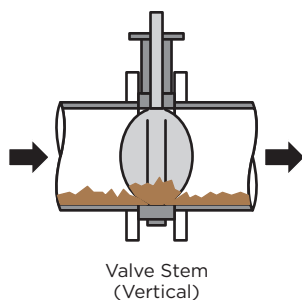

CORRECT

Sediment passes under disc.

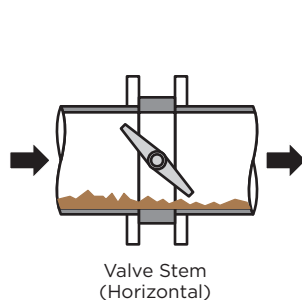

4-Cx DOUBLE OFFSET BUTTERFLY VALVES

Installation, Operation and Maintenance Manual



9.4 Valve Orientation (Continued)

Butterfly valves located at the discharge of a pump should be oriented as follows:

Figure 4: Centrifugal pump (with pump shaft horizontal).

INCORRECT
Valve stem horizontal.

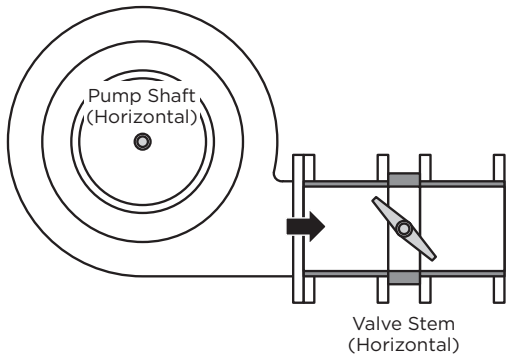

CORRECT
Valve stem vertical.

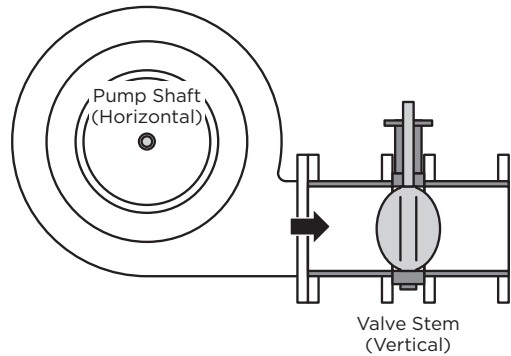
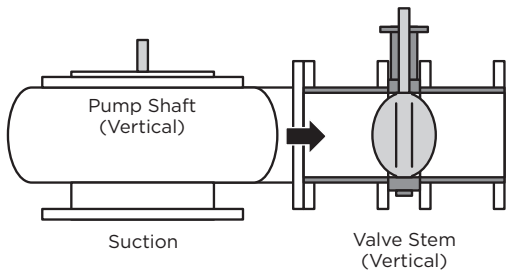

Figure 5: Centrifugal pump (with pump shaft vertical).

INCORRECT
Valve stem horizontal.



CORRECT
Valve stem vertical.

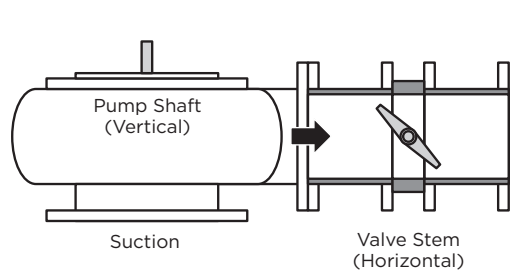
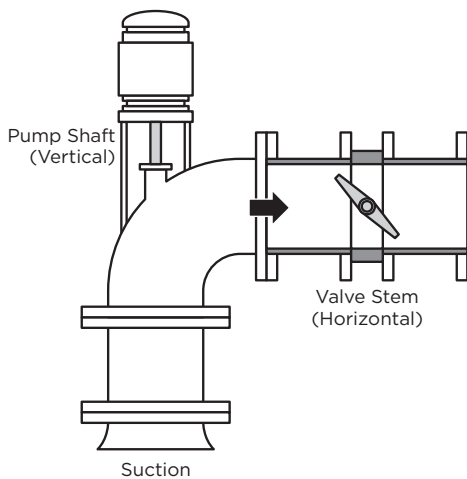
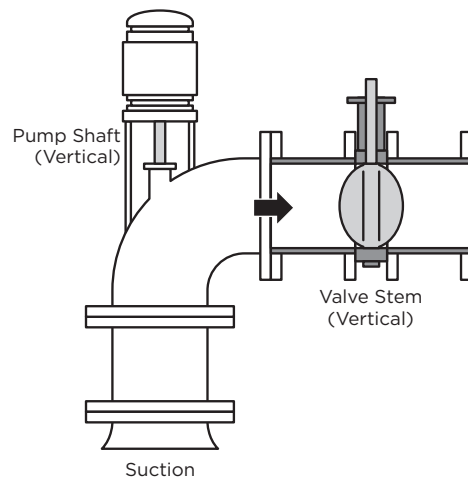

Figure 6: Axial pump (with pump shaft vertical).

INCORRECT
Valve stem horizontal.



CORRECT
Valve stem vertical.



4-Cx DOUBLE OFFSET BUTTERFLY VALVES

Installation, Operation and Maintenance Manual



9.4 Valve Orientation (Continued)

Butterfly valves located downstream of a bend, tee, or reducer should be oriented as follows:

Figure 7: Bend.

INCORRECT
Valve stem horizontal.

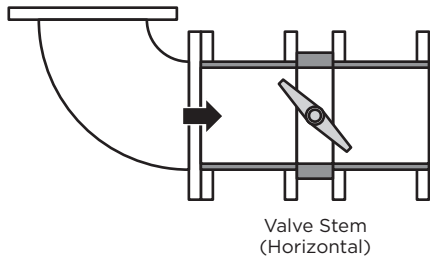

CORRECT
Valve stem vertical.

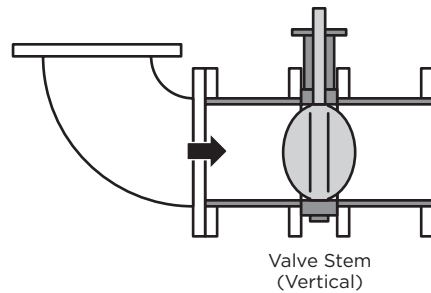
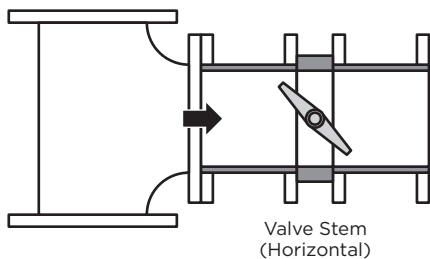

Figure 8: Tee.

INCORRECT
Valve stem horizontal.



CORRECT
Valve stem vertical.

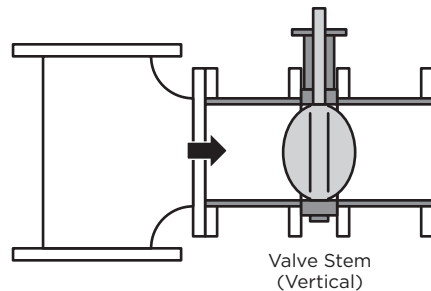
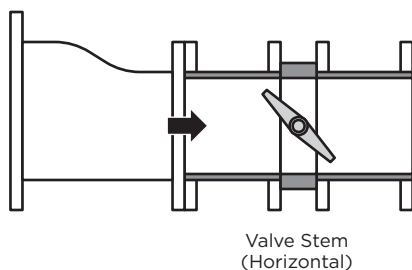
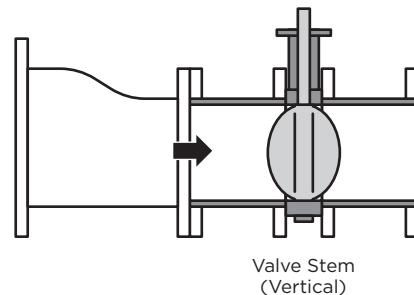

Figure 9: Reducer.

INCORRECT
Valve stem horizontal.



CORRECT
Valve stem vertical.



9.4 Valve Orientation (Continued)

Butterfly valves installed in a control/isolation combination should be oriented as follows:

Figure 10: Control/Isolation combination.



INCORRECT

Combination with all valve stems in the same direction accelerates possible noise, vibration, and erosion problems.

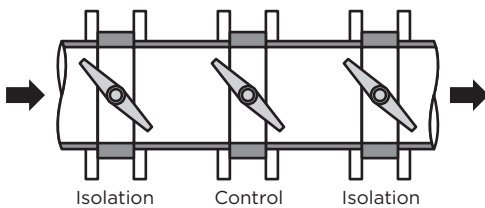

CORRECT

Combination with the stem of the control valve at right angle to those of other valves tends to cancel the drift of the fluid, and reduces noise, vibration, and erosion.

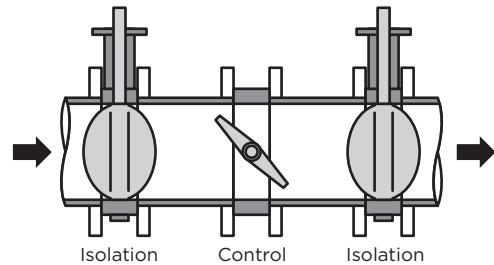

10.0 INSTALLATION PROCEDURE

10.1 Inspect the pipeline and pipe flange faces and ensure they are clean. Any foreign material such as pipe scale, metal chips, welding slag, welding rods, etc., can obstruct disc movement or damage the disc or seat.

10.2 With the disc in closed position, carefully center valve between flanges. Guide holes (wafer-type valve) or tapped holes (lug-type valves) to match pipe flanges and assist in positive alignment.

NOTE: Flange gaskets are not generally included in the scope of supply of this valve. Flange gaskets should conform to EN1514-1 flat seal with form IBC or form FF.

10.3 Use flange gasket manufacturer's standard torque values when bolting valve into the line. The seat is sufficiently compressed by the seat retainer and additional force from flange bolting is not required.

4-Cx DOUBLE OFFSET BUTTERFLY VALVES

Installation, Operation and Maintenance Manual



11.0 OPERATION

11.1 Operation

Operation of the valve is done by turning the stem a quarter-turn (90 degree turn).

- > The stem is turned clockwise to close, counter-clockwise to open.

11.2 Valve Open/Closed Indication

Double-D Indication

- > Valve **OPEN** position: Flats of Double-D stem are **parallel** to pipeline.
- > Valve **CLOSED** position: Flats of Double-D stem are **perpendicular** to pipeline.

Keyed Indication

- > Valve **OPEN** position: Key is **parallel** to pipeline.
- > Valve **CLOSED** position: Key is **perpendicular** to pipeline.



CAUTION

Valves with actuators should be inspected for actuator/valve alignment. Misalignment will result in high operational torque and damage to valve stem and seals.

Figure 11: Indication of valve Open and Closed position.

Double-D Stem

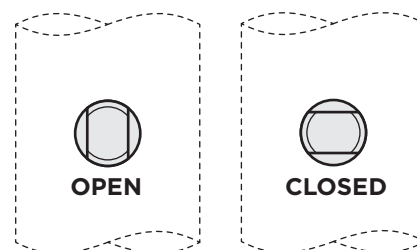
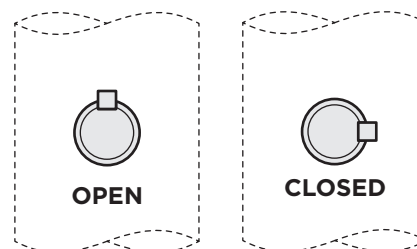

Figure 12: Indication of valve Open and Closed position.

Keyed Stem



12.0 MAINTENANCE



WARNING

Reasonable precautions should be taken before beginning work on the valve. Protective clothing, as required by the specific line fluid, should be worn.

Before opening the valve for maintenance, all valves used in applications with dangerous media must be decontaminated (flushed and cleaned under safe conditions).

Before removing handle or the actuator from the valve, or before removing seat retainer from a valve in dead end service, close the valve and depressurize the line.

Do not pressurize the line without a handle or actuator on the valve.



CAUTION

The eccentric design of the valve may allow line pressure to open the valve if the handle/actuator is not in place while the valve is under pressure.

When handling the valve, care should be taken not to scratch the disc edge or seat.

The valve must be in the closed position to be removed from the line.



NOTICE

For valves supplied to ATEX standards, check assembly for grounding strap before removing from pipeline.

12.1 Begin all work on a valve that has been removed from service by cleaning the valve, removing any grit or scale.

12.2 Replacement seats, seals and other parts are available from authorized distributors. Contact your distributor or sales representative for details on price and delivery.

13.0 OPERATOR REMOVAL AND REMOUNTING



NOTICE

For this section, “operator” refers to any device used to operate the valve, such as a handlever, gearbox, or actuator.

“Operator assembly” refers to the operator and any additional mounting brackets, top plates, spacer plates, etc.

Refer to the operator installation, operation, and maintenance instructions before proceeding.

13.1 Removing Operator

Neutralize all energy sources (electrical, mechanical, and pneumatic/hydraulic pressure).

Support the operator assembly before disconnecting it from the body assembly.

Unbolt the operator assembly from valve body.

Lift operator assembly off stem.

13.2 Remounting Operator

Before mounting an operator on the valve body, verify that the segment orientation matches the desired operator rotation and complies with the operator failure mode requirements.

Slide the entire operator assembly onto the stem.

Bolt operator assembly to valve body.

Verify and set operator stops.



NOTICE

Refer to the operator installation, operation, and maintenance instructions for necessary adjustments.

14.0 STEM SEAL REPLACEMENT



WARNING

Ensure the fluid system is de-pressurized or isolated from any internal pressure before beginning any service on the valve.

14.1 Disassembly

Remove operator assembly and stem key, if present.

Loosen each gland retainer cap screw two to three turns to relieve internal pressure from the encapsulated stem seal chamber.

Remove gland retainer cap screws.

Remove gland retainer (with installed set screws and gland retainer o-ring). Disassemble set screws and gland retainer o-ring from gland retainer.

Remove travel stop (with installed travel stop o-ring). Remove travel stop o-ring from travel stop.

Remove stem o-ring, gland washer, and grounding spring.



NOTICE

Grounding spring may get caught in stem o-ring groove. If this occurs, carefully disengage grounding spring from stem o-ring groove.

Remove disc springs and gland ring.

NOTE: Two M6 tapped holes are provided on gland ring top surface to assist in removing gland ring if needed.

Use an appropriate packing disassembly tool (such as corkscrew or hook tool) to remove and discard the stem seals.



CAUTION

Extreme care should be taken not to damage/scratch the body and stem sealing surfaces.

Remove thrust washer.

14.2 Cleaning

Wipe each component clean from any foreign media or excess thread lubricant with a clean cloth.

4-Cx DOUBLE OFFSET BUTTERFLY VALVES

Installation, Operation and Maintenance Manual



14.3 Assembly



CAUTION

Inspect all o-rings for any excessive wear or damage. If damage exists, replace with new o-ring.



NOTICE

Stem seal components should be installed with the valve in the vertical position.

Install thrust washer and new stem seals.

- > Install first stem seal with flat bottom on top of the thrust washer.
- > Install remaining stem seals. (Refer to **Table 2** for total quantity of seal rings in each valve.)

Install gland ring and disc springs.

NOTE: Refer to **Figure 13** and **Table 3** for quantity and orientation of disc springs.

Figure 13: Disc spring orientation.
(Series x Parallel)

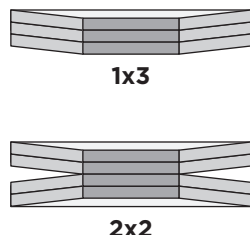

Table 2: TOTAL NUMBER OF STEM SEALS

Valve Size DN	PN 10	PN 16	PN 25	PN 40
80	4	4	4	4
100	4	4	4	4
150	4	4	4	4
200	5	5	5	5
250	5	5	5	5
300	5	5	5	5
350	5	5	5	5
400	5	5	5	5

Table 3: DISC SPRING QUANTITY & ORIENTATION

Valve Size	Valve Class	Qty	Series x Parallel
DN 80	PN 40	4	2x2
	PN 10	4	2x2
DN 100	PN 40	4	2x2
	PN 10	4	2x2
	PN 16	4	2x2
	PN 25	4	2x2
DN 150	PN 40	4	2x2
	PN 10	4	2x2
	PN 16	4	2x2
	PN 25	4	2x2
DN 200	PN 40	4	2x2
	PN 10	4	2x2
	PN 16	4	2x3
	PN 25	4	2x2
DN 250	PN 40	4	2x2
	PN 10	4	2x2
	PN 16	4	2x2
	PN 25	4	2x2
DN 300	PN 40	3	1x3
	PN 10	4	2x2
	PN 16	4	2x2
	PN 25	4	2x2
DN 350	PN 40	3	1x3
	PN 10	3	1x3
	PN 16	3	1x3
	PN 25	3	1x3
DN 400	PN 40	3	1x3
	PN 10	6	1x3
	PN 16	6	1x3
	PN 25	6	1x3

4-Cx DOUBLE OFFSET BUTTERFLY VALVES

Installation, Operation and Maintenance Manual



Pre-assemble grounding spring into gland washer groove and slide assembly over stem. (**Figure 14**)



NOTICE

Grounding spring may get caught in stem o-ring groove. If this occurs, carefully disengage grounding spring from stem o-ring groove.

An assembly sleeve tool may also be used to assist in installing gland washer and grounding spring assembly without getting stuck in stem o-ring groove.

Install stem o-ring into o-ring groove. (**Figure 14**)

Pre-assemble travel stop o-ring onto travel stop. With the disc/stem in the closed position, orient the travel stop as shown in **Figure 15**.

Slide travel stop and o-ring assembly onto valve stem until bottomed against stem shoulder surface.

Pre-assemble gland retainer o-ring into the gland retainer o-ring groove.

Note the location of the internal travel stop surfaces on the bottom of the gland retainer. (see **Figure 16**) Orient the gland retainer so that the internal travel stop surfaces are aligned with the travel stop flats. The marking on the gland retainer for the DN size and PN pressure should be facing the back side of the valve (opposite seat retainer side).

Install the gland retainer and gland retainer o-ring over the stem and travel stop with travel stop o-ring. Ensure gland retainer fits over travel stop o-ring without pushing it out of place or binding up.

Figure 14: Grounding spring position and assembly.

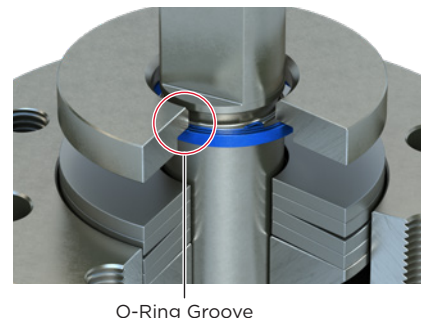

Figure 15: Internal travel stop orientation.

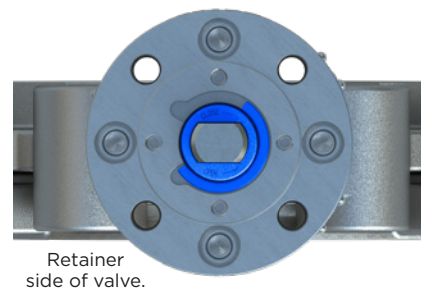
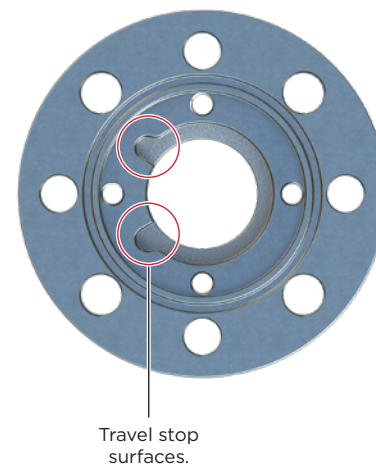

Figure 16: Gland retainer bottom face.



4-Cx DOUBLE OFFSET BUTTERFLY VALVES

Installation, Operation and Maintenance Manual



Coat each gland retainer cap screw (1/4 to 1/3 of the way up bottom thread) with anti-seize compound.

Install each gland retainer cap screw through the gland retainer holes and thread loosely into the body.

Tighten each gland retainer cap screw evenly in a crisscross sequence (**Figure 17**) until the gland retainer is metal-to-metal with the body. Do not exceed the torque values listed in **Table 4**.

Coat each set screw with a small amount of anti-seize compound.

Install each set screw into the gland retainer set screw holes and loosely tighten until set screw bottoms onto gland washer.

Tighten each set screw evenly in a crisscross sequence (**Figure 17**). Do not exceed the torque values listed in **Table 5**.

Install stem key into stem groove, if present. Remount operator assembly.

Figure 17: Example of crisscross tightening pattern.

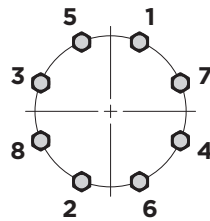

Table 4: CAP SCREW TIGHTENING TORQUE

Valve Size DN	Tightening Torque (N m)			
	Series 4E PN 10	Series 4G PN 16	Series 4J PN 25	Series 4L PN 40
80	20	20	20	20
100	20	20	20	20
150	20	20	20	20
200	20	20	20	20
250	20	20	20	20
300	20	20	20	20
350	20	20	20	20
400	40	40	40	40

Table 5: SET SCREW TIGHTENING TORQUE

Valve Size DN	Tightening Torque (N m)			
	Series 4E PN 10	Series 4G PN 16	Series 4J PN 25	Series 4L PN 40
80	10	10	10	10
100	10	10	10	10
150	10	10	10	10
200	10	10	10	10
250	10	10	10	10
300	10	10	10	10
350	24	24	24	24
400	47	47	47	47

15.0 SEAT REPLACEMENT

15.1 Disassemble the valve completely from flanges and place it on a flat level surface with the seat retainer facing up.

NOTE: Wood blocks may be used to help support and level the valve.

15.2 Check the position of the disc using a level to ensure disc is at the 0 degree closed position and is not under or over closed.

15.3 Disassembly

Disassemble each seat retainer cap screw a few turns at a time in a crisscross sequence (**Figure 17**) to evenly unload each cap screw.



CAUTION

Extreme care should be taken not to damage/scratch the disc sealing surfaces.

Remove the seat retainer and place on a soft surface with the flange gasket serrated surface facing down so that the back of the seat retainer can be cleaned, and the seat groove on the seat retainer does not get damaged.

Discard the seat.

15.4 Wipe each component clean from any foreign media or excess thread lubricant with a clean cloth.

15.5 Inspect the disc sealing surface to check for any scratches or other damage that could impact sealing performance. If damage is found, contact Bray for valve replacement.

Figure 17: Example of crisscross tightening pattern.

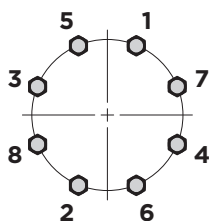

15.6 Assembly

Install the new seat. (It should sit loosely in a level position onto the disc sealing surface).

Lower the seat retainer carefully onto the seat (lining up the seat retainer cap screw holes with the threaded holes on the body) until the seat retainer sits centered onto the seat and body.



CAUTION

Extreme care should be taken not to damage/scratch the disc sealing surfaces.

Coat each seat retainer cap screw (1/4 to 1/3 of the way up bottom thread) with anti-seize compound.

Install each seat retainer cap screw through the seat retainer holes and thread loosely into the body.

Tighten each seat retainer cap screw evenly in a crisscross sequence (**Figure 17**) to the values listed in **Table 6**.

Figure 17: Example of crisscross tightening pattern.

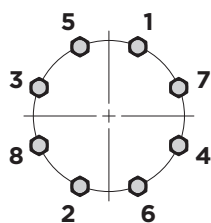

Table 6: SEAT RETAINER TIGHTENING TORQUE

Valve Size DN	Tightening Torque (N-m)			
	Series 4E PN 10	Series 4G PN 16	Series 4J PN 25	Series 4L PN 40
80	15	15	15	15
100	19	19	19	19
150	21	21	21	21
200	23	23	23	17
250	16	16	20	20
300	20	20	20	13
350	22	22	22	30
400	25	25	25	25

16.0 BOTTOM PLATE GASKET REPLACEMENT

16.1 Disassembly

Remove the bottom plate cap screws.

Remove the bottom plate and discard used bottom plate gasket.

Clean the gasket sealing surfaces on the body and bottom plate.

16.2 Assembly

Install new bottom plate gasket onto bottom plate.

Install bottom plate into body.

Coat each bottom plate cap screw (1/4 to 1/3 of the way up bottom thread) with anti-seize compound.

Install each bottom plate cap screw through the bottom plate and thread loosely into the body.

Tighten each bottom plate cap screw evenly in a crisscross sequence (**Figure 17**) until the bottom plate is metal-to-metal with the body. Do not exceed the torque values listed in **Table 7**.

Figure 17: Example of crisscross tightening pattern.

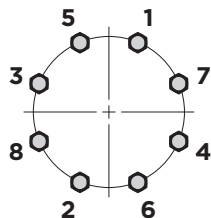

Table 7: BOTTOM PLATE TIGHTENING TORQUE

Valve Size DN	Tightening Torque (N m)			
	Series 4E PN 10	Series 4G PN 16	Series 4J PN 25	Series 4L PN 40
80	8	8	8	8
100	8	8	8	8
150	8	8	8	20
200	8	8	8	20
250	20	20	20	20
300	20	20	20	40
350	20	20	40	40
400	70	70	70	70

4-Cx DOUBLE OFFSET BUTTERFLY VALVES

Installation, Operation and Maintenance Manual



17.0 TROUBLESHOOTING

SYMPTOM	POSSIBLE CAUSE	RECOMMENDED SOLUTION
Stem leakage	Gland retainer cap screws are loose.	Check and tighten per Table 4 .
	Set screws are loose.	Check and tighten per Table 5 .
Disc in fully closed position, seat leakage observed	Seat is worn or damaged.	Remove valve and inspect. Replace seat if damaged.
	Disc is damaged.	Remove valve and inspect. Replace valve if disc is damaged.
High torque during valve seating and unseating	Entrapped foreign media in pipeline prohibiting valve from seating.	a) Remove valve from service. b) Review disc to seat interface.
Valve pops during open and close	Superstructure fasteners loosened.	Tighten the superstructure fasteners.
	Insufficient air actuator supply.	Pneumatic operated valves: Increase supply pressure.
	Solenoid valve dust accumulation.	Remove and clean solenoid valve.
	Actuator piston rod seal damaged.	Replace seal.
Bottom plate leakage	Bottom plate bolts are loose.	Check and tighten per Table 7 .
	Bottom plate gasket is damaged.	Replace bottom plate gasket.

Note: For further troubleshooting and repair options and information, please contact your local Bray representative.

Table 4: CAP SCREW TIGHTENING TORQUE

Valve Size DN	Tightening Torque (N m)			
	Series 4E PN 10	Series 4G PN 16	Series 4J PN 25	Series 4L PN 40
80	20	20	20	20
100	20	20	20	20
150	20	20	20	20
200	20	20	20	20
250	20	20	20	20
300	20	20	20	20
350	20	20	20	20
400	40	40	40	40

Table 5: SET SCREW TIGHTENING TORQUE

Valve Size DN	Tightening Torque (N m)			
	Series 4E PN 10	Series 4G PN 16	Series 4J PN 25	Series 4L PN 40
80	10	10	10	10
100	10	10	10	10
150	10	10	10	10
200	10	10	10	10
250	10	10	10	10
300	10	10	10	10
350	24	24	24	24
400	47	47	47	47

Table 7: BOTTOM PLATE TIGHTENING TORQUE

Valve Size DN	Tightening Torque (N m)			
	Series 4E PN 10	Series 4G PN 16	Series 4J PN 25	Series 4L PN 40
80	8	8	8	8
100	8	8	8	8
150	8	8	8	20
200	8	8	8	20
250	20	20	20	20
300	20	20	20	40
350	20	20	40	40
400	70	70	70	70

18.0 RETURN MERCHANDISE AUTHORIZATION

17.1 All products that are returned require a Return Merchandise Authorization (RMA). Contact a Bray representative for instructions and RMA forms to be completed prior to return of any product.

17.2 The following information must be provided when submitting RMA.

- > Serial number
- > Part number
- > Month and year of manufacture
- > Actuator specifics
- > Application
- > Media
- > Operating temperature
- > Operating pressure
- > Total estimated cycles (since last installation or repair)

NOTE: Product information is provided on identification tag attached to device.



NOTICE

Materials must be cleaned and sanitized prior to return. MSDS sheets and Declaration of Decontamination are required.

SINCE 1986, BRAY HAS PROVIDED FLOW CONTROL SOLUTIONS FOR A VARIETY OF INDUSTRIES AROUND THE WORLD.

VISIT **BRAY.COM** TO LEARN MORE ABOUT BRAY PRODUCTS AND LOCATIONS NEAR YOU.

GLOBAL HEADQUARTERS

Bray International, Inc.

13333 Westland East Blvd.

Houston, Texas 77041

Tel: +1.281.894.5454

All statements, technical information, and recommendations in this bulletin are for general use only. Consult Bray representatives or factory for the specific requirements and material selection for your intended application. The right to change or modify product design or product without prior notice is reserved. Patents issued and applied for worldwide. Bray® is a registered trademark of Bray International, Inc.

© 2024 BRAY INTERNATIONAL. ALL RIGHTS RESERVED. BRAY.COM

EN_IOM_4Cx_20240710



THE HIGH PERFORMANCE COMPANY

BRAY.COM