

---

**SERIES 70**  
**ELECTRIC ACTUATORS**  
TECHNICAL SALES MANUAL



---

**Bray**<sup>®</sup>

# CONTENTS

---

OVERVIEW . . . . .	3
FEATURES & BENEFITS . . . . .	4
PART NUMBERING SYSTEM . . . . .	6
ACTUATOR SPECIFICATIONS. . . . .	7
OPTIONS . . . . .	8
DIMENSIONS & WEIGHTS   IMPERIAL . . . . .	12
DIMENSIONS & WEIGHTS   METRIC . . . . .	15
TORQUE AND MOTOR DATA . . . . .	17
ACTUATOR MOUNTING - IMPERIAL . . . . .	18
ACTUATOR MOUNTING - METRIC . . . . .	19
STANDARD DRAWINGS. . . . .	20

## OVERVIEW

---

### OVERVIEW

Decades of Bray's proven success in electric actuation, combined with innovative engineering, has produced the Series 70 electric actuator. The Series 70 features on/off, modulating control or network controls and offers many advantages over other actuators including:

- > Lowest profile and lightest weight actuator on the market.
- > Simple finger or screwdriver adjustment of travel limit cams without interference from other components.
- > Highly visible valve status display on most units.
- > Design allows for ease of field startup, maintenance and upgrades.



### CERTIFICATIONS & APPROVALS

---

UL, CSA and CE approved (most 120V models)

---

UL approved (USA & Canadian Std) for hazardous location

---

70-24V: CE approved

---

S70-708 to S70-720: 120VAC  
Class I, DIV 1 & 2, Group C, D  
Class II, DIV 1 & 2, Group E, F, G

---

#### NOTES

A complete listing of certifications and approvals can be found at [BRAY.COM](http://BRAY.COM)

FEATURES

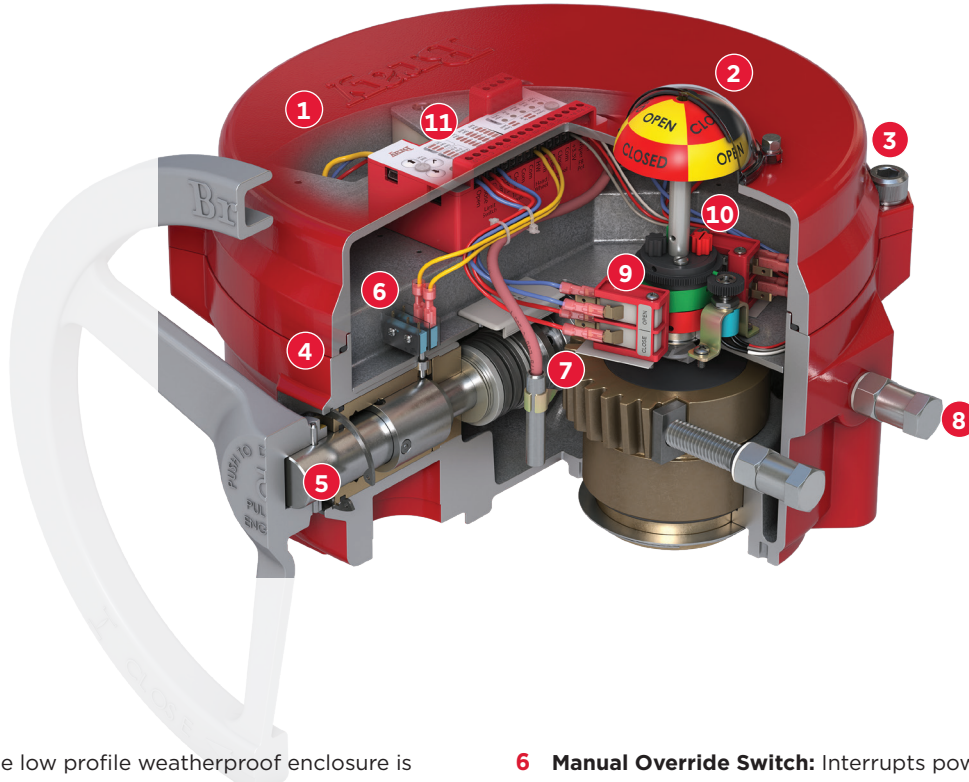

- 1 Enclosure:** The low profile weatherproof enclosure is UL listed Type 4, 4x and IP65, IP67 (S70-130/180 are not IP67). Polyester powder coated die-cast aluminum cover and base, for exceptional corrosion, wear, impact and ultraviolet resistance.
- 2 High Visibility Position Indicator:** Prominently labeled and color coded yellow for open, red for close - the display indicates valve position through the full range of travel. The O-ring sealed dome is made of high impact, heat, chemical and ultraviolet resistant clear polycarbonate and designed to withstand caustic wash down ensuring excellent corrosion protection.
- 3 Captive Cover Bolts:** The cover is attached to the base by captive stainless steel bolts placed outside the sealing area.
- 4 O-Ring Seal For Watertight Enclosure:** The O-ring seal between the cover and base provides a weatherproof seal preventing internal corrosion.
- 5 Manual Override:** Standard on all models. The declutchable manual override prevents handwheel movement during motor operation. When manual operation is desired, pull the handwheel out to expose the yellow stripe around the handwheel shaft, which indicates the handwheel is engaged and manual operation is available.
- 6 Manual Override Switch:** Interrupts power to the motor when handwheel operation is engaged.
- 7 Output Drive:** Self-locking worm shaft and worm gear assembly holds the valve in desired position.
- 8 Mechanical Travel Stop Bolts:** Designed to prevent over-travel in the open or close direction during manual operation. Travel stop bolts include a locknut to prevent loosening, seals to prevent water ingress, and spacers to prevent adjustment between 0° and 90° limit switch settings. Travel stop bolts permit 5° of over travel.
- 9 Limit Switch Bracket:** Simple and secure design to firmly hold limit switch assemblies for accurate and repeatable valve position feedback.
- 10 Limit Switch CAMs:** Bray's patented CAM design includes standard green (open) and red (close) CAMs which are adjustable with finger touch or screwdriver. No additional tools necessary. Standard factory setting allows 90° travel between open and close positions.
- 11 Optional Actuator Controls**  
**Servo NXT Modulating Controller:** 120, 220, 24 VAC  
 50/60 Hz, 1 phase 24 VDC  
**24V On/Off Controller:** (not shown)

FEATURES

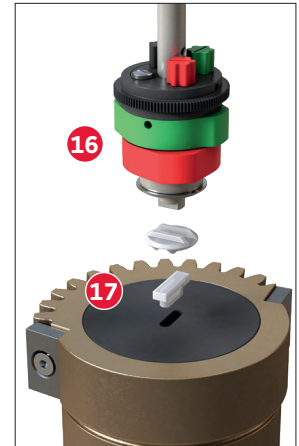
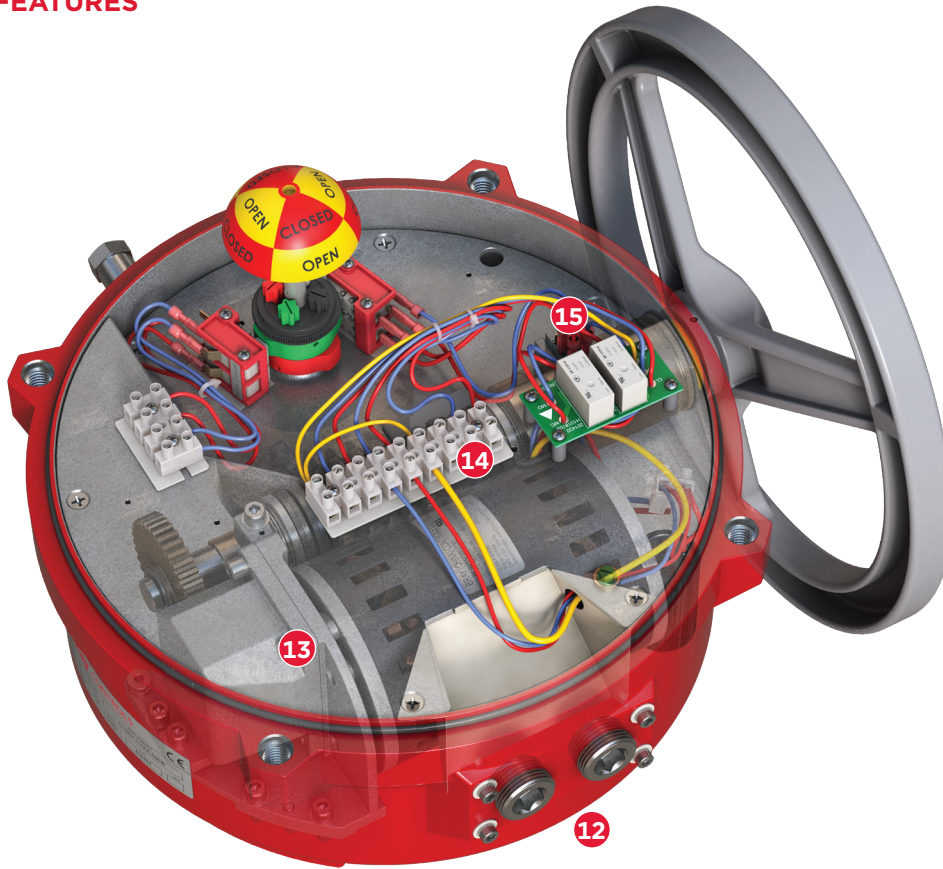

**12 Conduit Entries:** Two connections in either NPT or metric threads. One entry is for power, the other for control wiring.

**13 Motor Gear:** High torque start motor assembly, designed for fast inspection and maintenance.

**14 Terminal Strip:** Actuator limit switches are pre-wired to an easily accessible and clearly marked terminal block for customer wiring. The terminal strip has been placed near the two conduit entries with ample room for running wire leads. An easily accessible green plated ground screw is provided. A wiring diagram is included inside the cover for easy reference.

**15 Standard Actuator Control Interposing Relay Board (I.R.B.):** 120/220 VAC 50/60Hz On/Off control

**16 Roller Bearing:** Provides low friction while securely aligning actuator indicator shaft and CAMs for reliable valve position feedback.

**17 Oldham Coupler:** Corrects any misalignment between the valve and actuator without introducing side load to the position indicator shaft assembly.

## PART NUMBERING SYSTEM

Series	Torque		X - Speed		Product		Y - Style		Z - Voltage		TTT - Trim	
70	E03	300 lb-in	0	60 sec	113	Actuator	G	Imperial, Servo NXT	A	120VAC	536	Standard Bray Red
	E06	600 lb-in	1	30 sec			R	Metric, Servo NXT	B	220VAC		
	E08	800 lb-in	6	110 sec			D	Imperial, IRB	C	24VAC/VDC	5F5	Bray Seacorr Coating
	E12	1200 lb-in					N	Metric, IRB	D	24VDC		
	E20	2000 lb-in							0	120VAC		
	E30	3000 lb-in							3	24VAC/VDC		
	050	5000 lb-in							4	220VAC		
	065	6500 lb-in										
	13W	13000 lb-in										
	18W	18000 lb-in										

### W - Designates The Output Bore Diameter

0	2.5 Inches (63.5mm)
1	1.97 Inches (50 mm)

Actuator Size	Part Number	Torque	
		lb-in	N m
S70-E03	70-E03X-113YZ-TTT	300	34
S70-E06	70-E06X-113YZ-TTT	600	68
S70-E08	70-E08X-113YZ-TTT	800	90
S70-E12	70-E12X-113YZ-TTT	1,200	136
S70-E20	70-E20X-113YZ-TTT	2,000	226
S70-E30	70-E30X-113YZ-TTT	3,000	339
S70-050	70-050X-113YZ-TTT	5,000	565
S70-065	70-065X-113YZ-TTT	6,500	734
S70-130	70-13WX-113YZ-TTT	13,000	1469
S70-180	70-18WX-113YZ-TTT	18,000	2034

Style / Voltage		Voltage	Speed 1/4 Turn Seconds (60 Hz)	Controller
Imperial	Metric			
DA	NA	120VAC	30*	Interposing Relay Board (IRB)
DB	NB	220VAC	30*	Interposing Relay Board (IRB)
DC	NC	24VAC/VDC <sup>1</sup>	60	On/Off with Controller
DD	ND	24VDC	60	No Controller
G0	R0	120VAC	30*	Modulating with Servo NXT
G3	R3	24VAC/VDC	60	Modulating with Servo NXT
G4	R4	220VAC	30*	Modulating with Servo NXT
F3	Q3	24VAC/VDC	60	On/Off NXT Controller

<sup>1</sup>S70-050 is only 24VAC

\*S70-130, 131 and 180, 181 are 110 seconds

Note: 220VAC units are 230VAC compatible



# ACTUATOR SPECIFICATIONS

## SPECIFICATIONS

<b>Output Torque</b>	120/230 V	300 to 18,000 lb-in (34-2034 N m)
	24 V	600, 800, 2,000, 5,000 lb-in (68, 90, 226, 565 N m)
<b>Control Options</b>	On/Off	Interposing Relay Board (I.R.B) 120/230 VAC  On/Off NXT Controller 24VAC/DC
	Modulating	Servo NXT Controller 120/230 VAC/24 VAC/DC 4-20 Ma, 0-10 V, 0-5 V, 2-10 V
	Communication Protocol	EtherNet/IP
<b>Voltages</b>	120/230 VAC 50/60 Hz, 1-phase  24 VAC/VDC	
<b>Enclosure Ratings</b>	NEMA 4, 4x, and IP65, IIP67 (IP67 does not include S70-130/131 and 180/181)	
<b>Mounting</b>	ISO5211	
<b>Motor</b>	120/230 VAC: 1-phase, reversible, permanent split capacitor induction motor	
	24 V: Permanent magnet brushed DC Motor	
<b>Temperature Range</b>	-22°F to +150°F -29°C to +65°C	
<b>Switch Options</b>	2 SPDT mechanical switches standard	
	Additional auxiliary switches available (up to 6 total)	
	Optional torque switches available	
<b>Duty Rating</b>	On/Off Application	Per EN15714-2 Class A
	Modulating Applications	Per EN15714-2 Class C

## CONSTRUCTION

<b>Housing</b>	ASTM B85 pressure die cast aluminum Polyester powder coated Nylon 11 coated (optional)
<b>Exposed Fasteners</b>	Stainless Steel
<b>Travel Stops</b>	Externally adjustable at both 0 and 90 degrees
<b>Conduit Entries</b>	S70-E03 to S70-E08: 2 x 1/2" NPT or 2 x M20 S70-E12 to S70-180: 2 x 3/4" NPT or 2 x M25
<b>Worm Gearing</b>	Worm: Chromoly, self locking Worm gear: Aluminum bronze
<b>Spur Gearing</b>	AGMA class 9, nitride hardened alloy steel
<b>Bearings</b>	Indicator shaft and motor gear: Permanently sealed ball bearing Worm shaft: Sintered bronze bushing with heavy duty thrust bearing
<b>Lubrication</b>	High temperature synthetic grease
<b>Motor</b>	120/230 VAC: Single phase, reversible, permanent split capacitor induction motor 24V: Permanent magnet-brushed DC motor
<b>Capacitor</b>	110/230 VAC: Metalized polyester
<b>Heater</b>	Optional, 5 watt PTC style
<b>Terminal Strip</b>	Switch Plate: 12 - 22 AWG (2.0 - 0.65mm) Servo: 14 - 24 AWG (1.63 - 0.51mm)
<b>Torque Limiting</b>	Optional, open and close preset at factory
<b>Limit Switches</b>	SPDT: 120VAC -10A-1/3 HP 220VAC -10A-1/2 HP 250VDC - 1/4A 12VDC - 2A

## PERFORMANCE

<b>Output Torque</b>	See Torque Chart
<b>Voltages</b>	See Motor Chart
<b>Ambient Temperature</b>	-20°F to 150°F -29°C to 65°C
<b>Motor Insulation</b>	120/220 VAC: Class F, 311°F (155°C) thermal trip at 275°F (135°C) 24V: Class B Fast blow fuse 5A@250VAC
<b>On/Off Applications</b>	Per EN15714-2 Class A
<b>Modulating Applications</b>	Per EN15714-2 Class C
<b>Manual Operation</b>	Pull to engage, push to disengage
<b>Enclosure</b>	Designed to meet NEMA Type 4, 4x and IP65/67 specifications

## OPTIONS

### SERVO NXT

The Servo NXT offers precise modulating service for accurate position control.

- > One touch automatic calibration
- > User-friendly interface
- > Advanced control of proportional band and dead band
- > Automatic pulsing mode for precise positioning
- > Self diagnostics
- > Action on loss of command signal
- > Go to position commands

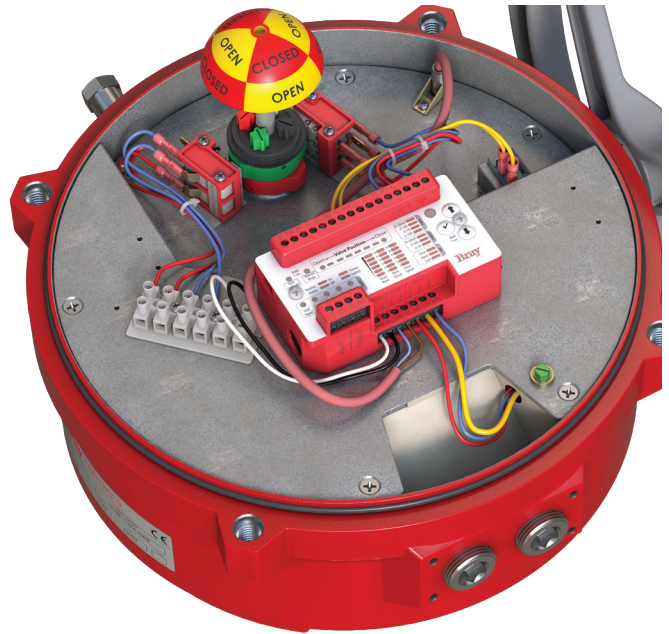

### SERVO NXT FEATURES / SPECIFICATIONS

<b>Actuator Voltage</b>	120, 220, 24 VAC 50/60 Hz, 1 phase 24 VDC
<b>Input Signal</b>	Configurable 4-20 mA, 0-10, 2-10, 0-5 VDC
<b>Retransmission Signal</b>	Configurable 4-20 mA, 0-10, 0-5 VDC
<b>Independent Isolation</b>	Control signal input and output Control signals and power
<b>Display</b>	Menu driven auto dimming LED
<b>Menu Navigation</b>	Up/Down arrows with select (3) buttons
<b>Configuration</b>	Menu selectable to non-volatile memory
<b>Calibration</b>	Auto calibration sequence for travel limits
<b>Deadband</b>	Configurable 1% - 6%
<b>Reverse Acting</b>	Configurable for inverted input signal
<b>Speed Control</b>	Independent for open and close direction
<b>Fail Position (loss of input signal)</b>	Configurable close, open, last
<b>Manual Mode</b>	Local operation via Servo NXT user interface
<b>Fault Indications</b>	Loss of command signal Limit switch Handwheel engaged Feedback pot Torque switch Jammed valve / motor stalled
<b>Health Monitor</b>	Heartbeat - Backlit blinking Bray logo

"Configurable" means the customer, or the factory, can modify the Servo NXT.



## OPTIONS

### BATTERY BACKUP UNIT (BBU)

Designed for use with 24V actuators, the optional BBU provides power to permit the actuator to reach its fail-open or fail-close position in the event of a main power failure. Upon reaching the fail position, the BBU turns off until external power is restored. After main power has been restored, the actuator returns to normal operation.



### CONSTRUCTION AND PERFORMANCE

<b>Housing</b>	ASTM B85 pressure die cast aluminum Polyester powder coated Nylon 11 coated (optional)
<b>Exposed Fasteners</b>	Stainless steel
<b>Batteries</b>	Two 12V 1.4AH sealed lead acid batteries wired in series
<b>Battery Monitoring</b>	Local LED indicator and voltage free 2-wire normally open contact for remote monitoring
<b>Battery Charging</b>	Automatic smart charge
<b>Battery Conservation</b>	Shut-off batteries after one minute or when actuator stops
<b>Operating Temperature</b>	-4°F (-20°C) to 122°F (50°C) LED light may not function below -20°F (-29°C)
<b>Power Protection</b>	Two 5 amp fuses, one for the external power output circuit and the other for the battery output circuit
<b>Current Draw @ 24 VAC</b>	BBU only maximum 10mA standby (0.25 VA) Max. 420mA charging (10 VA)
<b>Current Draw of Actuator with BBU</b>	600 lb-in - 1.9A (with load) 2,000 lb-in - 2.7A (with load) 5,000 lb-in - 4.1A (with load)
<b>Power Requirements</b>	24-27VAC or 30-38VDC (the minimum voltage is required to provide proper battery charging) Use dedicated Class 2 non-bonded transformer rated 100VA per BBU
<b>Power Output</b>	BBU output with 24VAC supply is 30-38 VDC On failure of AC supply, battery output is 24-25.5 VDC BBU will provide fail open or fail close operation

### BATTERY SPECIFICATIONS

<b>Batteries</b>	Two 12 volt 1.4 ampere-hour (AH) rechargeable sealed lead acid battery wired in series
<b>Features</b>	Valve regulated, spill proof construction allows safe operation in any position Rugged impact resistant ABS case and cover (UL94-HB) U.L. Recognized under file number MH 20845
<b>Specifications</b>	Battery case: ABS plastic Maximum discharge current (7 minutes): 4.2 amperes Shelf Life (% of nominal capacity at 68°F (20°C) 1 month = 97% 3 months = 91% 6 months = 83%
<b>Operating Temperature</b>	Charge: -4°F to 122°F (-20°C to 50°C) Discharge: -40°F to 140°F (-40°C to 60°C) The BBU should be powered up for a minimum of 12 hours

## OPTIONS

### 1 - HEATER

Mounted on the actuator switch plate, a self-regulating heater can be added to prevent potential electrical component damage due to condensation build-up inside the actuator.

### 2 - POTENTIOMETER

Optional gear driven 10k ohm potentiometer provides continuous position feedback for a customer control system. Potentiometer is standard with the Servo NXT controller.

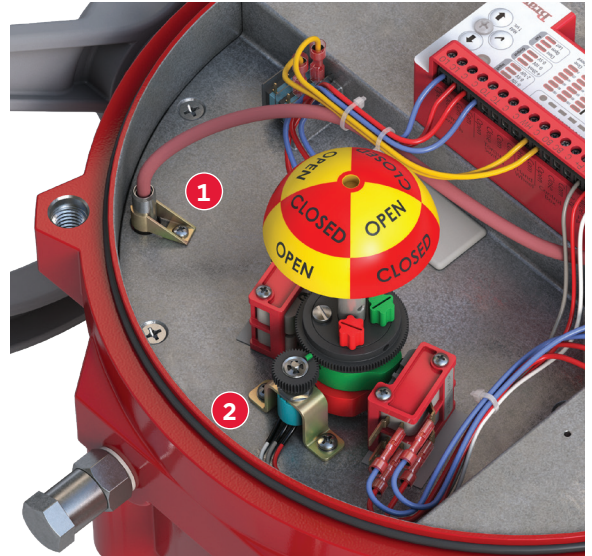

### AUXILLARY SWITCHES

Up to four additional dry-contact (voltage free) SPDT mechanical switches can be added to indicate travel position for remote customer control systems.

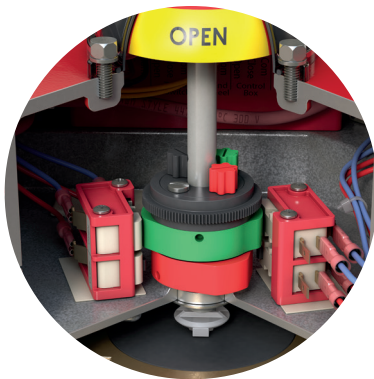

### TORQUE SWITCH

Optional torque switches provide protection for the automated valve assembly in the event of an over-torque event.



## OPTIONS

### CONTROL STATION

The optional control station features a local-off-remote control switch, an open-stop-close switch, and two lights which locally indicate open and close valve position. This weatherproof aluminum enclosure is easily bolted to the four mounting holes located on the S70 conduit entry panel. The Control Station cover includes captive bolts and may be rotated in 90° increments allowing the customer to easily operate and view the control station. Two ¾" NPT cable entries are available in the control station base. Two different multi-pin, weatherproof electrical cable connections are also available.



### ELECTRICAL CABLE CONNECTIONS

Pre-wired multi-pin weatherproof cable receptacles allow quick-connect field installation and prevent internal cabling errors which could occur during commissioning. Cord sets can be supplied with connection/flying leads or connection/connection on cord set ends to plug directly into the actuator receptacle.



Optional Seacorr® Coating

WEATHERPROOF NEMA TYPE 4, 4X & IP65, IP67 - E03 TO 065

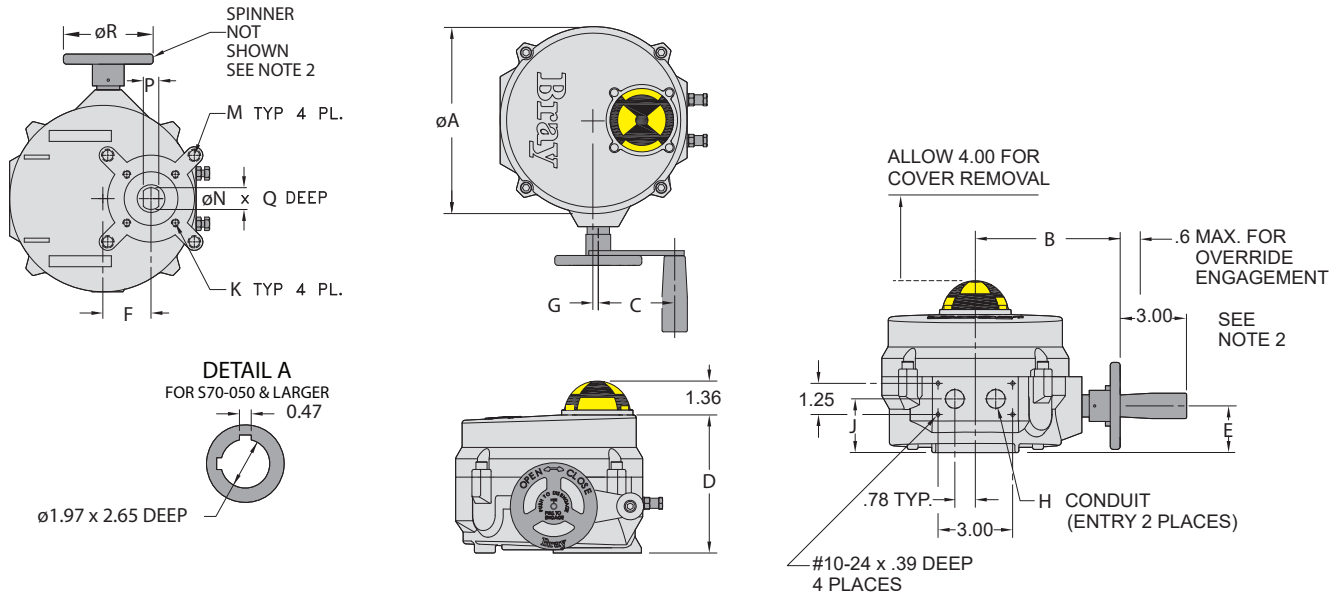

IMPERIAL DIMENSIONS - Inches																		
Actuator Size	Torque (lb-ins)	A	B	C	D	E	F	G	H NPT	J	K (UNC) x B.C.	M (UNC) x B.C.	N	P	Q	øR	Wt. lbs	
S70-E03	300																	
S70-E06	600	7.5	5.8	3.0	5.6	1.9	1.94	.19	1/2	2.2	5/16-18 x ø2.76	—	.75	.51	1.75	3.5	13	
S70-E08	800																	
S70-E12	1,200																	
S70-E20	2,000	10.1	7.8	3.7	6.6	2.4	2.69	.56	3/4	2.6	5/16-18 x ø2.76	1/2-13 x ø4.92	1.18	.87	2.22	8.0	28	
S70-E30	3,000																	
S70-050	5,000	12.1	9.5	5.5	7.2	2.9	3.19	.56	3/4	3.1	1/2-13 x ø4.92	3/4-10 x ø6.50	See Detail A			12.0	48	
S70-065	6,500																	

Notes:

1. On/Off Applications - Per EN15714-2 Class A
2. Modulating Applications - Per EN15714-2 Class C
3. Handwheel Spinner shown in drawing is available as an option.
4. Dimension (N) is also available with Double Square (Star) drive.

Drawings are for reference only.

Please refer to Bray ES and GA drawings on the Bray website, [www.bray.com](http://www.bray.com).

Bray reserves the right to change product dimensions without notice.

WEATHERPROOF NEMA TYPE 4, 4X & IP65 - S70-130/131 AND S70-180/181

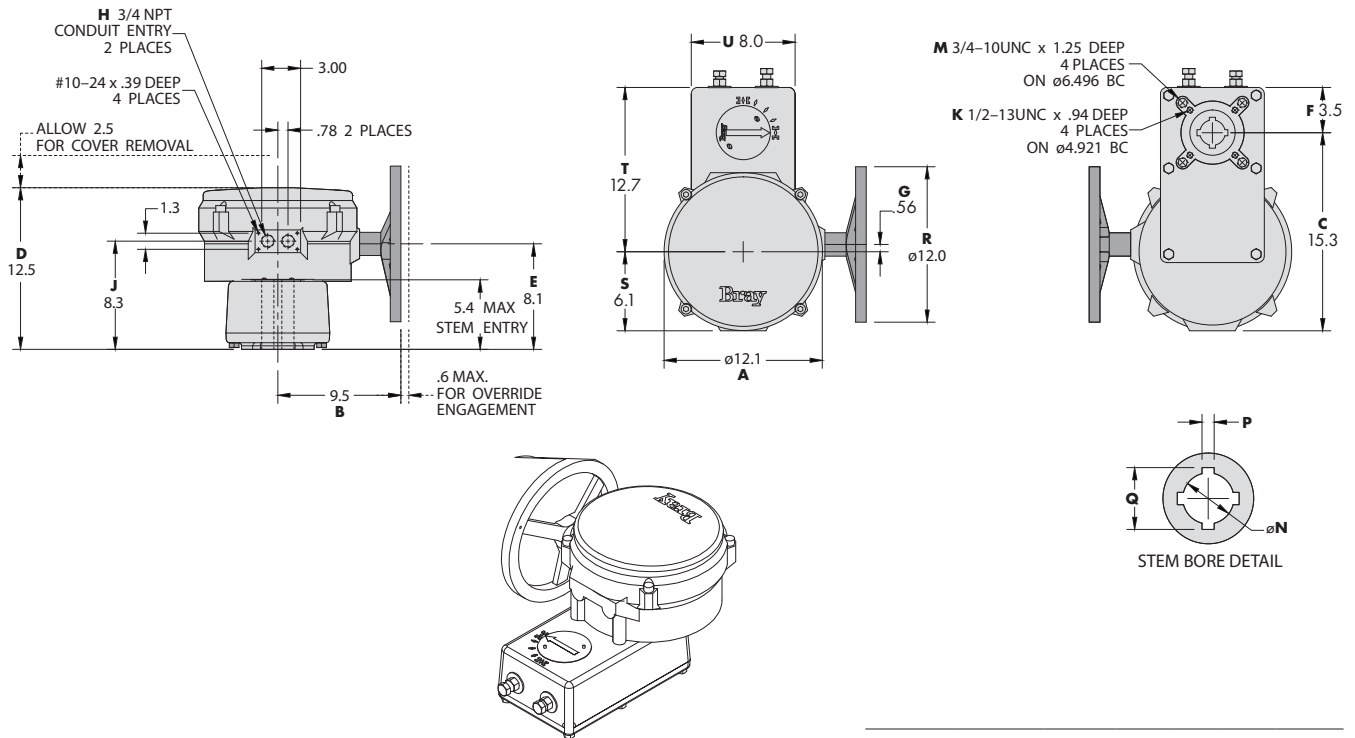

STEM BORE DETAIL						
Size	Torque lb-ins.	Speed sec.	N	P	Q	Wt. lbs
70-1306	13,000	110	2.51	0.63	3.05	118
70-1316	13,000	110	1.97	0.47	2.38	118
70-1806	18,000	110	2.51	0.63	3.05	118
70-1816	18,000	110	1.97	0.47	2.38	118

IMPERIAL DIMENSIONS - Inches

Actuator Size	A	B	C	D	E	F	G	H NPT	J	K (UNC) x B.C.	M (UNC) x B.C.	N	P	Q	øR	S	T	U	Wt. lbs
S70-130/131 S70-180/181	12.1	9.5	15.3	12.5	8.1	3.5	.56	3/4	8.3	1/2-13 x ø4.921 F12	3/4-10 x ø6.496 F16	See Stem Bore Detail			12.0	6.1	12.7	8.0	118

Notes:

1. On/Off Applications - Per EN15714-2 Class A
2. Modulating Applications - Per EN15714-2 Class C
3. Dimension (N) is also available with Double Square (Star) drive.

Drawings are for reference only. Please refer to Bray ES and GA drawings on the Bray website, [www.bray.com](http://www.bray.com).

Bray reserves the right to change product dimensions without notice.

HAZARDOUS LOCATION, WEATHERPROOF NEMA TYPE 4, 4X & IP65 - S70-708 TO S70-720

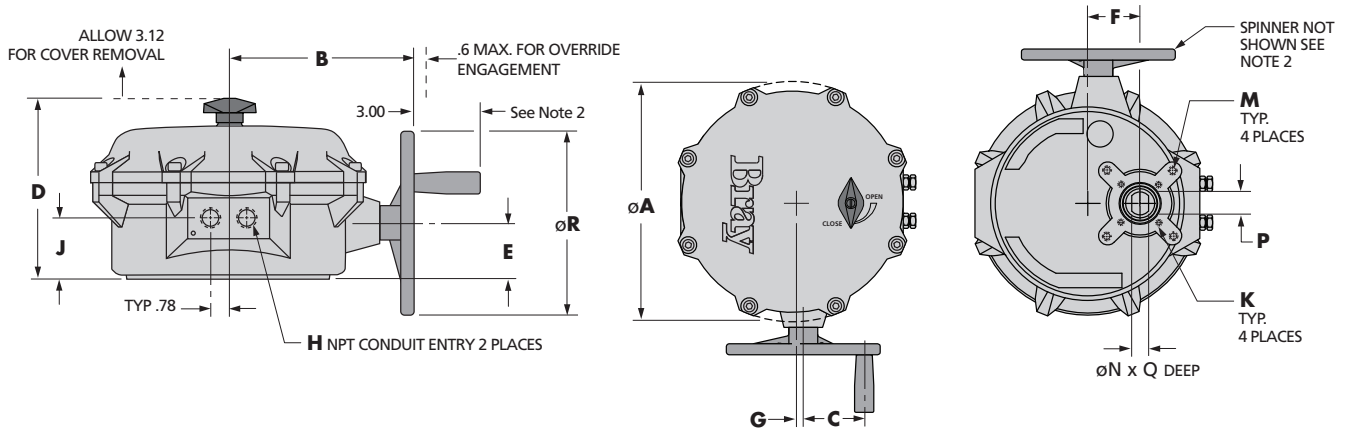

IMPERIAL DIMENSIONS - Inches																	
Actuator Size	Torque (lb-ins)	A	B	C	D	E	F	G	H	J	K (UNC) x B.C.	M (UNC) x B.C.	N	P	Q	øR	Wt. lbs
S70-708	800																
S70-712	1200	12.5	8.0	3.7	7.7	2.4	2.69	.56	3/4	2.6	5/16-18 x ø2.76 F07	1/2-13 x ø4.92 F12	1.18	.87	2.01	8.0	34
S70-720	2000																

- Notes:**
1. On/Off Applications - Per EN15714-2 Class A
  2. Modulating Applications - Per EN15714-2 Class C
  3. Handwheel Spinner shown in drawing is available as an option.

Drawings are for reference only. Please refer to Bray ES and GA drawings on the Bray website, [www.bray.com](http://www.bray.com).

Bray reserves the right to change product dimensions without notice.



WEATHERPROOF NEMA TYPE 4, 4X & IP65/IP67 - E03 TO 065

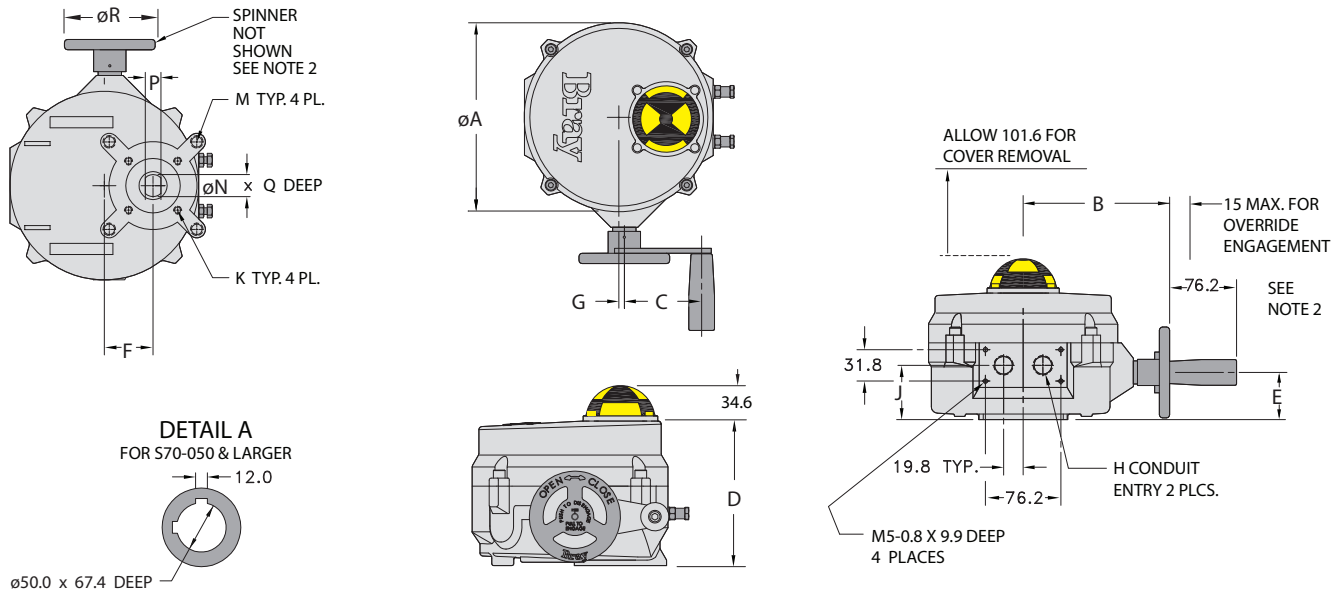

METRIC DIMENSIONS - Millimeters

Actuator Size	Torque (Nm)	øA	B	C	D	E	F	G	H	J	K x B.C.	M x B.C.	N	P	Q	øR	Wt. kgs
S70-E03	34																
S70-E06	68	191	147	76	141	48	49.2	4.7	M20 x 1.5	55	M8 x 1.25 x ø70	—	19.0	13.0	44.5	89	6
S70-E08	90																
S70-E12	136																
S70-E20	226	256	198	93	168	62	68.3	14.3	M25 x 1.5	66	M8 x 1.25 x ø70	M12 x 1.75 x ø125	30.0	22.0	56.3	203	13
S70-E30	339																
S70-050	565	308	241	139	183	73	80.9	14.3	M25 x 1.5	78	M12 x 1.75 x ø125	M20 x 2.5 x ø165	See Detail A			305	22
S70-065	734																

Notes:

1. On/Off Applications - Per EN15714-2 Class A
2. Modulating Applications - Per EN15714-2 Class C
3. Handwheel Spinner shown in drawing is available as an option.
4. Dimension (N) is also available with Double Square (Star) drive.

Drawings are for reference only. Please refer to Bray ES and GA drawings on the Bray website, [www.bray.com](http://www.bray.com).

Bray reserves the right to change product dimensions without notice.

WEATHERPROOF NEMA TYPE 4, 4X & IP65 - 70-130/131 AND S70-180/181

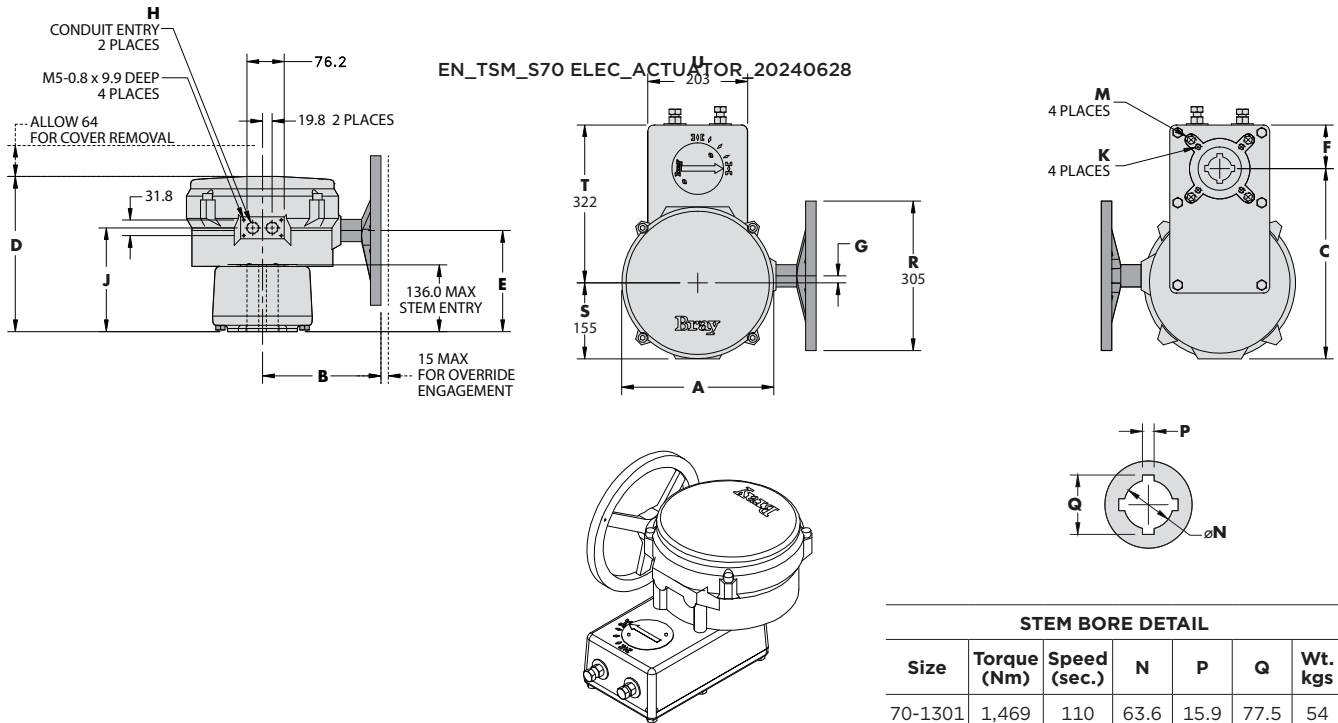

STEM BORE DETAIL						
Size	Torque (Nm)	Speed (sec.)	N	P	Q	Wt. kgs
70-1301	1,469	110	63.6	15.9	77.5	54
70-1311	1,469	110	50.0	12.0	60.6	54
70-1801	2,034	110	63.6	15.9	77.5	54
70-1811	2,034	110	50.0	12.0	60.6	54

METRIC DIMENSIONS - Millimeters

Actuator Size	A	B	C	D	E	F	G	H	J	K (MM) x B.C.	M (MM) x B.C.	N	P	Q	ØR	S	T	U	Wt. kgs
S70-130/131 S70-180/181	308	241	389	316	206	89	14.3	1.5	212	12 x 125 BC x 23.9	20 x 165 BC x 31.8	See Stem Bore Detail	305	155	322	203	54		

Notes:

1. Modulating Applications - Per EN15714-2 Class C
2. Dimension (N) is also available with Double Square (Star) drive.

Drawings are for reference only. Please refer to Bray ES and GA drawings on the Bray website, [www.bray.com](http://www.bray.com).

Bray reserves the right to change product dimensions without notice.

# TORQUE AND MOTOR DATA

		S70-E03	S70-E06	S70-E08	S70-E12	S70-E20	S70-E30	S70-050	S70-065	S70-130	S70-180	S70-708*	S70-712*	S70-720*
Torque	lb-in	300	600	800	1200	2000	3000	5000	6500	13000	18000	800	1200	2000
	N m	34	68	90	136	226	339	565	734	1469	2034	90	136	226
Actuator Approx. Wt.	lb	11	11	11	25	25	25	45	45	118	118	25	25	25
	kg	5	5	5	11	11	11	20	20	54	54	11	11	11

## MANUAL OVERRIDE

Handwheel Diameter	in	3.5	3.5	3.5	8	8	8	12	12	12	12	8	8	8
	mm	89	89	89	203	203	203	305	305	305	305	203	203	203
Gear Ratio		30:1	30:1	30:1	30:1	30:1	30:1	30:1	30:1	90:1	90:1	30:1	30:1	30:1
Rim Pull	lb	16	32	43	28	46	70	62	80	80	80	18	28	46
	kg	7.3	14.5	19.5	12.7	20.9	31.8	28.1	36.3	36.3	36.3	8.2	12.7	20.9

\* Hazardous Location Units

## 120VAC

Travel Time 90° sec.		Current Draw in Amps																											
		S70-E03		S70-E06		S70-E08		S70-E12		S70-E20		S70-E30		S70-050		S70-065		S70-130		S70-180		S70-708*		S70-712*		S70-720*			
60 Hz	50 Hz	FLA	LRA	FLA	LRA	FLA	LRA	FLA	LRA	FLA	LRA	FLA	LRA	FLA	LRA	FLA	LRA	FLA	LRA	FLA	LRA	FLA	LRA	FLA	LRA	FLA	LRA	FLA	LRA
30	36	0.70	1.00	0.75	1.00	0.80	1.00	0.75	2.10	0.85	2.10	1.00	2.10	1.60	3.00	2.30	3.10					0.60	2.10	0.78	2.10	1.00	2.10		
110	132																	2.30	3.10	2.50	3.10								

## 220VAC

Travel Time 90° sec.		Current Draw in Amps																											
		S70-E03		S70-E06		S70-E08		S70-E12		S70-E20		S70-E30		S70-050		S70-065		S70-130		S70-180		S70-708*		S70-712*		S70-720*			
60 Hz	50 Hz	FLA	LRA	FLA	LRA	FLA	LRA	FLA	LRA	FLA	LRA	FLA	LRA	FLA	LRA	FLA	LRA	FLA	LRA	FLA	LRA	FLA	LRA	FLA	LRA	FLA	LRA	FLA	LRA
30	36	0.40	0.75	0.42	0.75	0.44	0.75	0.35	0.90	0.40	0.90	0.45	0.90	0.90	1.40	1.10	1.40					0.38	0.90	0.45	0.90	0.50	0.90		
110	132																	1.30	2.70	1.50	2.70								

\* Hazardous Location Units

FLA - Full Load Amps

LRA - Locked Rotor Amps

24VAC	S70-E06	S70-E08	S70-E20	S70-050
Current	FLA	FLA	FLA	FLA
	2.40	2.90	3.50	4.00
Operating Speed	35	40	60	85

24VDC	S70-E06	S70-E08	S70-E20	S70-050
Current	FLA	FLA	FLA	FLA
	1.90	2.40	2.70	3.10
Operating Speed	50	60	80	90

Hazardous Location Units

FLA - Full Load Amps

LRA - Locked Rotor Amps

For all other information such as dimensional drawings, wiring diagrams, and EDS files please visit [bray.com](http://bray.com) or contact your local Bray representative.

**IMPERIAL (in.)**

Actuator Size	Inner Bolt Circle			Outer Bolt Circle				Stem Hole				
	Bolt Circle	No. Holes	Bolt Size	Bolt Circle	No Holes	Bolt Size	Dia.	Across Flats	Depth	Keyway Width		
S70-E03	F07	2.76	4	5/16-18	-	-	-	-	0.75	0.51	1.75	-
S70-E06	F07	2.76	4	5/16-18	-	-	-	-	0.75	0.51	1.75	-
S70-E08	F07	2.76	4	5/16-18	-	-	-	-	0.75	0.51	1.75	-
S70-E12	F07	2.76	4	5/16-18	F12	4.92	4	1/2-13	1.18	0.87	2.20	-
S70-E20	F07	2.76	4	5/16-18	F12	4.92	4	1/2-13	1.18	0.87	2.20	-
S70-E30	F07	2.76	4	5/16-18	F12	4.92	4	1/2-13	1.18	0.87	2.20	-
S70-050	F12	4.92	4	1/2-13 18	F16	6.50	4	3/4-10	1.97	-	2.60	2 x 7/16
S70-065	F12	4.92	4	1/2-13 18	F16	6.50	4	3/4-10	1.97	-	2.60	2 x 7/16
S70-130	F12	4.92	4	1/2-13 18	F16	6.50	4	3/4-10	1.97	-	5.40	4 x 7/16
S70-131	F12	4.92	4	1/2-13 18	F16	6.50	4	3/4-10	1.97	-	5.40	4 x 5/8
S70-180	F12	4.92	4	1/2-13 18	F16	6.50	4	3/4-10	1.97	-	5.40	4 x 7/16
S70-181	F12	4.92	4	1/2-13 18	F16	6.50	4	3/4-10	1.97	-	5.40	4 x 5/8
S70-708	F07	2.76	4	5/16-18	F12	4.92	4	1/2-13	1.18	0.87	2.20	-
S70-712	F07	2.76	4	5/16-18	F12	4.92	4	1/2-13	1.18	0.87	2.20	-
S70-720	F07	2.76	4	5/16-18	F12	4.92	4	1/2-13	1.18	0.87	2.20	-

METRIC (mm)

Actuator Size	Inner Bolt Circle			Outer Bolt Circle			Stem Hole					
	Bolt Circle	No. Holes	Bolt Size	Bolt Circle	No. Holes	Bolt Size	Dia.	Across Flats	Depth	Keyway Width		
S70-E03	F07	70	4	M8 x 1.25	-	-	-	-	19	13	44.5	-
S70-E06	F07	70	4	M8 x 1.25	-	-	-	-	19	13	44.5	-
S70-E08	F07	70	4	M8 x 1.25	-	-	-	-	19	13	44.5	-
S70-E12	F07	70	4	M8 x 1.25	F12		4	M12 x 1.25	30	22	55.9	-
S70-E20	F07	70	4	M8 x 1.25	F12	125	4	M12 x 1.25	30	22	55.9	-
S70-E30	F07	70	4	M8 x 1.25	F12	125	4	M12 x 1.25	30	22	55.9	-
S70-050	F12	125	4	M12 x 1.25	F16	165	4	M20 x 1.75	50.04	-	66	12.0
S70-065	F12	125	4	M12 x 1.25	F16	165	4	M20 x 1.75	50.04	-	66	12.0
S70-130	F12	125	4	M12 x 1.25	F16	165	4	M20 x 1.75	50.04	-	137.2	12.0
S70-131	F12	125	4	M12 x 1.25	F16	165	4	M20 x 1.75	63.5	-	137.2	16.0
S70-180	F12	125	4	M12 x 1.25	F16	165	4	M20 x 1.75	50.04	-	137.2	12.0
S70-181	F12	125	4	M12 x 1.25	F16	165	4	M20 x 1.75	63.5	-	137.2	16.0
S70-708	F07	70	4	M8 x 1.25	F12	125	4	M12 x 1.25	30	22	55.9	-
S70-712	F07	70	4	M8 x 1.25	F12	125	4	M12 x 1.25	30	22	55.9	-
S70-720	F07	70	4	M8 x 1.25	F12	125	4	M12 x 1.25	30	22	55.9	-

**Standard Dimensional Drawings**

Imperial Standard	GA-53561
Metric Standard	GA-53560
Imperial Hazardous Location	ES11A-0526
Imperial 13,000-18,000 lb-in	ES11A-0708
Metric 13,000-18,000 lb-in	ES12A-0708

**Standard Wiring Diagrams**

<b>Voltage</b>	<b>Duty</b>	<b>Controller</b>	<b>Aux Limit Switches</b>	<b>Diagram Number</b>
120/220 VAC	On/Off	IRB	NO	WD-000044
120/220 VAC	On/Off	IRB	YES	WD-000045
120/220 VAC	Modulating	Servo NXT	NO	WD-000338
120/220 VAC	Modulating	Servo NXT	YES	WD-000339
24 VAC/VDC	On/Off	ON/OFF NXT	YES	WD-000528
24 VAC/VDC	On/Off	ON/OFF NXT	NO	WD-000560
24 VAC/VDC	Modulating	Servo NXT	YES	WD-000561
24 VAC/VDC	BBU On/off	ON/OFF NXT	YES	WD-000581



---

SINCE 1986, BRAY HAS PROVIDED FLOW CONTROL SOLUTIONS FOR A VARIETY OF INDUSTRIES AROUND THE WORLD.

VISIT **BRAY.COM** TO LEARN MORE ABOUT BRAY PRODUCTS AND LOCATIONS NEAR YOU.

## **HEADQUARTERS**

**Bray International, Inc.**

13333 Westland East Blvd.

Houston, Texas 77041

Tel: +1.281.894.5454

All statements, technical information, and recommendations in this bulletin are for general use only. Consult Bray representatives or factory for the specific requirements and material selection for your intended application. The right to change or modify product design or product without prior notice is reserved. Patents issued and applied for worldwide. Bray® is a registered trademark of Bray International, Inc.

© 2024 BRAY INTERNATIONAL, INC. ALL RIGHTS RESERVED. BRAY.COM

EN\_BR\_TSM\_\_S70 Electric Actuator\_20240628

---



**THE HIGH PERFORMANCE COMPANY**

**BRAY.COM**