

Double Acting/Spring Return

SERIES 92 DAB / SERIES 93 SRB DIMENSIONS

Optional Extreme Temperature Trim Available in These Sizes Only

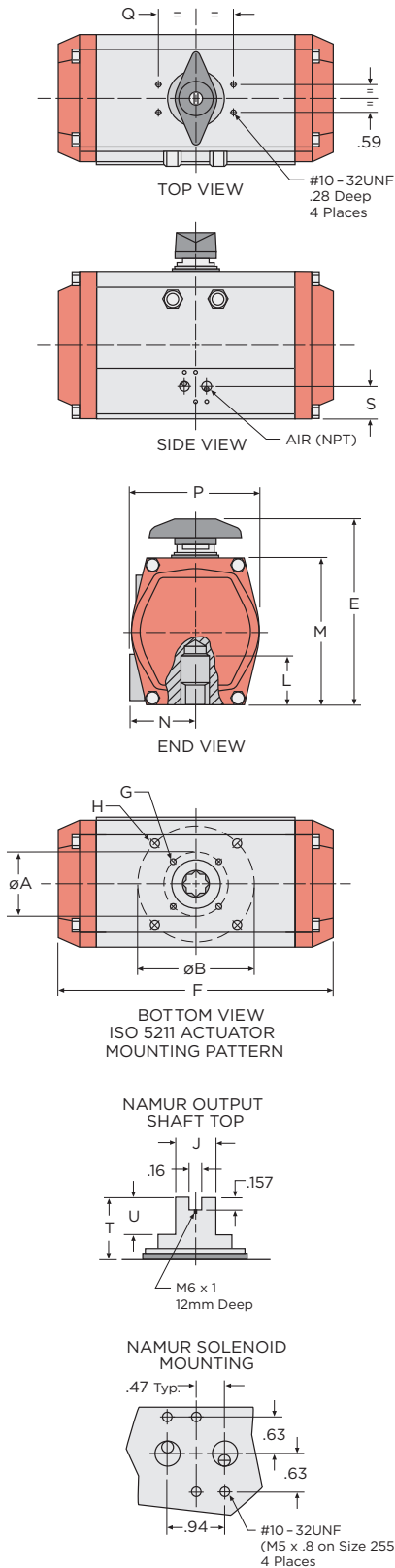

SIZE	48 **Double Acting	63	83	93	119	128	160	210	255B
AIR NPT	1/8	1/4	1/4	1/4	1/4	1/4	1/4	1/4	1/4
A ISO "F"	1.42 F 03	1.97 F 05	1.97 F 05	1.97 F 05	2.76 F 07	2.76 F 07	—	4.92 F 12	6.50 F 16
B ISO "F"	1.97 F 05	2.76 F 07	2.76 F 07	2.76 F 07	4.92 F 12	4.92 F 12	4.92 F 12	6.50 F 16	7.87x4.72 Rect
C	.71	.71	.87	.87	1.42	1.42	1.42	2.37	2.84
D	.55	.55	.67	.67	1.06	1.06	1.06	1.81	2.17
E	3.88	4.53	5.43	5.78	7.28	8.09	9.36	11.45	13.35
F	4.00	5.58	7.40	9.10	12.40	12.81	15.54	19.48	26.70
G (UNC)	10-32 x .23	1/4-20 x .32	1/4-20 x .32	1/4-20 x .32	5/16-18 x .46	5/16-18 x .46	—	1/2-13 x .78	M20x2.5 x 30mm
H (UNC)	1/4-20 x .25	5/16-18 x .40	5/16-18 x .40	5/16-18 x .40	1/2-13 x .69	1/2-13 x .69	1/2-13 x .75	5/8-11 x 1.11	M20x2.5 x 30mm
J	.38	.38	.50	.50	1.12	1.12	1.12	1.12	1.12
L	.58	0.63	0.75	1.18	1.59	1.59	1.59	2.61	2.61
M	2.50	3.46	4.27	4.61	5.52	6.32	7.80	10.04	11.89
N	1.60	1.72	2.02	2.47	2.78	2.88	3.07	4.25	4.75
P	2.78	3.11	3.83	4.44	5.15	5.58	6.82	8.83	10.75
Q	3.15	3.15	3.15	3.15	3.15	3.15	5.12	5.12	5.12
S	1.25	.89	.89	1.32	1.64	1.64	1.39	1.44	1.50
T	1.10*	.79	.79	.79	.79	.79	1.18	1.18	1.18
U	.47	.47	.47	.47	.47	.47	.75	.75	.75

Note: Double Acting and Spring Return actuators have the same overall dimensions.

* Size 48 has a T dimension of .79 with use of NAMUR top plate.

**For Spring Return dimensions for size 48, please consult factory.

† ISO "F" means mounting flange-drilling pattern.

Actuator Speed(s)

SIZE	48	63	83	93	119	128	160	210	255
Open Stroke/ Close Stroke	1/4	1/4	1/4	1/4	1/2	1/2	1	2	2 3/4

Times are in seconds, at 80 PSIG with 6ft. tubing, internal diameter approximately 1/4".

Actuator Weights (lb)

SIZE	48	63	83	93	119	128	160	210	255
DAB	1.8	3.4	6.1	8.4	16.4	20.9	38.1	65.0	144.0
SRB	2.4	4.1	7.9	10.8	21.7	27.3	52.6	95.3	192.6

Weights are in lbs. Spring Return unit weights are with full set of springs per piston.

Actuator Volumes (in³)

SIZE	48	63	83	93	119	128	160	210	255
Counter-clockwise	5.7	9.6	24.8	34.8	73.8	96.7	187.5	360.0	750.0
Clockwise	4.8	13.4	32.6	45.9	95.5	130.8	259.6	450.0	900.0

Counter-clockwise: Air volume in cubic inches required to push pistons apart, full travel.

Clockwise: Air volume in cubic inches required to push pistons together, full travel.

Temperature Ranges by Trim

Standard	-4°F to 200°F (-20°C to 93°C)
Low	-40°F to 176°F (-40°C to 80°C)
High	0°F to 300°F (-18°C to 149°C)
Extreme High	0°F to 350°F (-18°C to 176°C) 4 hours at 482°F (250°C)

STANDARD MATERIALS

Body	Extruded aluminum alloy, anodized
End Caps	Die cast aluminum alloy with corrosion resistant polyester coating
Pistons	Die cast aluminum alloy
Output Shaft/Pinion	Carbon Steel, zinc plated
Travel Stop	Alloy Steel
Shaft Bearings	Acetal*
Piston Guides	Acetal*
Fasteners	Stainless Steel
Springs	Spring Steel, protective coating*
O-Ring Seals	Buna-N*
Options (Not available for extreme high temperature trim)	Polyester coated body exterior Electroless Nickel plated body exterior Hard Anodized body exterior Stainless Steel pinion

ACTUATOR COMPONENTS

Item	Qty.	Description
1	1	Body
2	2	Piston
3	1	Pinion
4	2	End Cap
5**	12 max.	Spring Cartridge Assembly*
6	1	Upper Bearing*
7	1	Lower Bearing*
8	1	Retaining Ring*
9	1	Nylon Washer*
10	2	Acetal-Bearing Pad*
11	2	Acetal-Guide Ring*
12	2	Stop Nut
13	2	Travel Stop Adjusting Screw
14	2	O-Ring-Travel Stop
15	1	Acetal Spacer
16	1	Travel Stop
17	8	Hex Head Cap Screw
18	8	Lock Washer
19	2	O-Ring-Piston
20	2	O-Ring-End Cap
21	1	O-Ring-Shaft-Top
22	1	O-Ring-Shaft-Bottom
23	1	Indicator Pointer*
24	1	Indicator Pointer Screw

*Extreme high temperature trim uses proprietary components
 **Not included in Double Acting unit.

SPECIFICATIONS - STANDARD TRIM ACTUATOR

The actuator shall be pneumatically operated and must travel a minimum of 90° in each direction and must be able to overtravel at 3% in each direction past 90°. The actuator shall be totally enclosed and contained in a single enclosure. All pneumatic passage ways must be integral to the actuator housing so as to eliminate the need for external tubing. Actuator shall be rack and pinion design, and the output torque shall be linear throughout travel. Actuator shall be provided with pistons that have acetal piston guides and rings thus greatly extending the life of the actuator and reducing friction to the minimum. Actuator must be supplied with two independent travel stop adjustment, the 0° and 90° travel positions have travel adjustments of +5° to -5° (see Diagram A below). The actuator shall be provided with mechanical visual position indicator, and the indicator must be able to be removed easily thus exposing the output shaft for use of manually overriding the actuator when needed. The output shaft and pinion must be of one piece and must be manufactured out of hardened alloy steel and zinc plated for corrosion protection. Actuator shall be able to mount in any position without loss of performance. Actuator housing shall be anodized aluminum and all external fasteners shall be stainless steel. Springs shall be spring steel, coated for corrosion protection. All seals shall be Buna-N and bearings made of lubricated acetal resin. The actuator shall be factory lubricated. Actuator design must have smooth housing lines so it will self-drain. The actuator shall be factory tested to ensure proper operation. Optional trims exist for low, high and extreme high temperature services

SPRING RETURN SYSTEM

The Spring Return System for fail-safe services must be installed in the same housing as the double acting actuator, with no additional housing extensions required, therefore saving weight and space. The spring system must be supplied as a self-contained spring cartridge system. This is a safety feature that ensures disassembly of the actuator without danger of spring release when end caps are removed. Actuator shall be Flow-Tek Automator Series or approved equal.

SERVICE DATA

Actuators shall be designed for pneumatic operation up to a maximum pressure of 140 PSIG (10 Bar) and for temperature ranges (shown in chart on page 1). Filtered air is recommended but not required. All double acting and spring return units shall be suitable for both on-off and throttling applications. Optional units shall be able to operate with other media such as hydraulic oil or water, consult factory for further information.

CAUTION: Before servicing actuators carefully read and understand all the instructions, warnings and cautions in the applicable Installation, Operation and Maintenance manual.

Diagram A
Travel Stop Adjustments

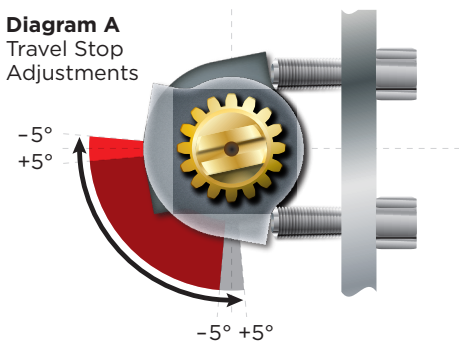

Spring Return Unit Shown

